



Circuit Breaker/Switchgear Renewal Parts Catalog

(Low, Medium, and High Voltage)



GE Support Services



GE Support Services

**For your parts needs,
call the GE Parts contact shown below:**



store.ips.us

**For more information contact your authorized
GE sales representative or GE distributor.**

**Visit the GE Support Services website at:
www.gess.ge.com**

GE Circuit Breaker/Switchgear Renewal Parts

GE Support Services

...dedicated to providing product support for GE parts and components and GE mature products. Trained sales and marketing specialists are ready to assist you with any product information inquiry. A \$25 million parts inventory insures the best possible service levels to you and your customer, and if we don't have the part in stock, our extensive database assists in locating the product you need or provides substitute items available immediately.

The following pages contain all presently available Switchgear parts that GE Support Services provides. Please contact your local GE distributor or a GE Sales representative regarding any questions you may have regarding all other GE renewal parts and components.

Features

Benefits

Extensive Inventory	—Fill all your parts needs immediately from an extensive stock inventory of over 12,000 items
In-house Parts Experts	—Our experts can assist with product identification, cost, and availability
24-hour Emergency Service	—Available seven days a week
Nationwide Communications Systems	—Tracks orders from entry to shipment so we can locate the parts you need and speed up the shipping process
Automated Warehouse	—Electronic linkage guarantees superior service on all stock and provides reliable, same-day/overnight delivery
Sourcing of Obsolete Parts	—With access to GE prints, GE Support Services can provide you with obsolete factory items
Full Factory Warranties	—Honor all warranties on parts sold through GE Support Services
Repair and Exchange Programs	—Choose from our repair-and-return option or our exchange plan for electronic boards for significant savings
Catalog Information	—Technical publications, catalogs, and price sheets

GE Support Services is your GE source for:

- Power Distribution Parts
 - Circuit Breaker
 - Switchgear
 - Transformer
 - Oil Cutouts
- Industrial Control Parts & Devices
- Drive Parts & Components
- Motor Parts
 - AC (Small, Medium & Large)
 - DC (Small, Medium & Large)
- Power Generation Parts
 - Turbine (Frames 3-2, 5-1 and 5-2)
 - GE Flame Tracker
- Specialty Products
 - Environmental Systems
 - GE Fanuc (Series 1, 1jr, 3 and 5)
 - GE Micro Switch Push Buttons
 - GE Push Buttons (CR103/104 & 080)
 - GE Starters/Contactors (CR700)
 - Molded Case Circuit Breakers (TEL, TEMPL, TFL)
 - Motor Starter Kits
 - Photoelectric Controls (357505/7511)
 - Power Fuses (9F60, 9F62)
 - Switches (QMR & SB)
 - Transportation (Switching Locomotive Parts)
 - Watt-hour Meters & Instruments

ISO 9002
CERTIFIED



GE Support Services

Courtesy of store.ips.us

GE Circuit Breaker/Switchgear Renewal Parts Catalog

Contents

Low Voltage Circuit Breaker Parts

1. AK-15/25 and AKR-30S Series Circuit Breakers1
2. AKR-30 and AK/AKR-50 Series Circuit Breakers13
3. AKS-50 and AK/AKR-75/100 Series Circuit Breakers37
4. Programmers and Related Parts67

Medium Voltage Circuit Breaker/Switchgear Parts

5. Power/Vac Vacuum Circuit Breaker/Switchgear73
ML-17 and ML-18 Mechanism
6. Magne Blast (Type AM) and GE/Vac Circuit Breakers/Switchgear87
7. Vertical Lift Metal-Clad Switchgear Parts103
M-26 and M-36

High Voltage Circuit Breaker Parts

8. Oil Distribution Circuit Breakers (14.4 to 25.8 kV)109
9. Vacuum Distribution Circuit Breakers (14.4 to 25.8 kV)113
10. Single Tank Oil Circuit Breakers (14.4 to 72.5 kV)117
11. Three Tank Oil Circuit Breakers (14.4 to 72.5 kV)123
12. Three Tank Oil Circuit Breakers (115 to 242 kV)129
13. Air Transmission Circuit Breakers (115 to 550 kV)141

Specialty Breaker Parts

14. DC Breakers147
MC-5 and MC-6; AG-7
15. Station Breakers171
16. Network Protectors203

Conversions/ Modifications/Other

17. Trip Device Conversion Kits219
18. AK/AKR Asbestos Free Arc Quencher Replacement Kits225
19. Other Factory Conversions and Upgrades227
20. Oil Cutouts229

WavePro™ 800-2000 Ampere Power Circuit Breakers

21. Back Frame Assembly and Components238
22. Front Frame Assemblies and Components242
23. Standard Parts and Assemblies243
24. Accessories248
25. Trip Units252

WavePro™ 3200-5000 Ampere Power Circuit Breakers

26. Back Frame Assembly and Components254
27. Front Frame Assembly and Components256
28. Standard Parts and Assemblies257
29. Accessories260
30. Trip Units, Rating Plugs, Target Modules265



GE Circuit Breaker/Switchgear Renewal Parts



store.ips.us



GE Support Services

Courtesy of store.ips.us

PowerVac® Vacuum Circuit Breaker

Included in this Section

PowerVac® metalclad switchgear combines the advantages of metalclad construction—flexibility and economy—with the benefits of vacuum interrupters—reliability, low maintenance, and reduced breaker size and weight. PowerVac® switchgear is designed for applications on 5-kV, 7.2-kV, and 15-kV power systems with available short-circuit capacities from 250 through 1000 MVA nominal.

- PowerVac® Vacuum Circuit Breaker with ML-17 Mechanism (VB)
- PowerVac® Vacuum Circuit Breaker with ML-18 Mechanism (VB1 & PVDB)

Equipment Identification and Nomenclature Guide

Equipment Serial Number, Mechanism Type, Amp Rating, Cycle Rating, and Control Voltage are most important for identification purposes. Breaker Nameplate is located on the lower front of the breaker.

Example: **VB-13.8-500-3000A-58-0**

Code	General Type	Mechanism
VB	Vacuum Breaker	ML-17
VB1	Vacuum Breaker	ML-18
PVDB	Power Vac Distribution Breaker	ML-18

Nominal Voltage
4.16
7.2
13.8

Nominal MVA
250
350
500
750
1000
1500

Continuous Current
1200
2000
3000

Rated Short-Circuit Current
58
63
66
77
78
100

Model Designator
-0, -1, -2, -3



GE Power Vac Breaker		TYPE	VB1 13.8-500-3
		SER. NO.	0357A4157-001-03
RATED MAX VOLTAGE	15 KV	RATED AMP.	1200 HZ 60
RATED SHORT CIRCUIT AMPS	18 KA	RATED VOLTAGE RANGE FACTOR	1.3
CLOSE COIL	0282A73406002 VOLTS	CLOSE & LATCH CAPABILITY AMP.	95 KV TIME 5 CYC
TRIP COIL	0282A70156006 VOLTS	CLOSING AMPS	6.0 VOLT RANGE 100-140
TRIP COIL	2	TRIPPING AMPS	7.3 VOLT RANGE 70-140
CHARGING MOTOR	0177C50506001 VOLTS	TRIPPING AMPS	
CONNECTION DIAGRAM	0209B8250P002	WT	470 LBS. MECH. TYPE ML-18 DATE MFG. 4/96
VAC. INTER. TYPE	50B1	REQ.	625-1222W SO: 977673
CAUTION: BEFORE INSTALLING OR OPERATING READ INST.		GEK-86132	GE ELECTRICAL DISTRIBUTION & CONTROL BURLINGTON, IOWA 52601 USA

Figure 5, PowerVac® Circuit Breaker Nameplate Data



GE Support Services

74 Medium Voltage Circuit Breaker/Switchgear Parts

Table 5-1, Power Vac® Vacuum Circuit Breaker with ML-17 Trip Mechanism

Fig. No.	Ref. No.	Description	Catalog Number
5A, 5B	1	Auxiliary Switch (Model Designator 0)	0209B3410P002
5A	1	Auxiliary Switch (Model Designator 1,2,3)	0209B3410P001
5C	2	Brake Assembly	0209B3617G001
5A, 5D	3	Charge-Discharge Flag Operating Rod	0282A2218P001
5A, 5B	4	Charging Motor	Table 5C
5A	5	Close Latch Checking Switch	0282A2005P002
5A	6	Closing Coil	Table 5D
5B, 5E	7	Closing Roller	0282S2000P100
5B, 5F	8	Closing Spring Assembly	0209B3526G002
5B, 5G	9	Closing Spring Gag Interlock	0282A2181P001
5A, 5B, 5H	10	Clutch Assembly for Motor (Model Designator 0,1,2)	0282A2402G001
5A, 5B, 5H	10	Clutch Assembly for Motor (Model Designator 3)	0282A2402G002
5A	11	Control Switch, Normally Closed	0282A2097P002
5A	11	Control Switch, Normally Open	0282A2097P003
5B, 5I	12	Coupling Clamp, Split Ring	0282A5061G003
5A, 5J	13	Dash Pot Assembly (Model Designator 1)	0209B3634G002
5A, 5J	13	Dash Pot Assembly (Model Designator 2,3)	0209B3724G001
5A, 5J	13	Dash Pot Assembly (Model Designator 0)	0209B3634G001
5A, 5B	14	Front Cover Assembly (Model Designator 0,1,2)	0209B3581G001
5A, 5B	14	Front Cover Assembly (Model Designator 3)	0209B3581G002
5B, 5L	15	Gear Motor Limit Switch Operator Assembly	0209B3626G001
5B	16	Ground Rod	0282A2147P001
5B, 5M	17	Negative Interlock Assembly	0177C2131G002
5B, 5N	18	Opening Stop Bolt Assembly	0282A5045G001
5A, 5B	19	Operating Rod	0209B3401G001
5A, 5O	20	Operation Counter	0282A2006P001
NI	21	Over Travel Stop Adjustment Bolt (1 3/4")	N176P2528B6
5B	21	Over Travel Stop Adjustment Bolt (2 1/8")	N176P2534B6
5B	21	Over Travel Stop Adjustment Bolt (2")	N176P2532B6
5B, 5P	22	Pin Connectors, Female (On Equipment)	0282A2081P002
5B, 5P	22	Pin Connectors, Male (On Breaker)	0282A2081P001
NI	-	Pin Retaining Rings, Assortment	0282A2015G001
5B	23	Primary Disconnect	Table 5F
5B, 5Q	24	Pull Rod (Model Designator 3)	0282A2476P002
5B, 5Q	24	Pull Rod (Model Designator 0,1,2)	0282A2476P001
5A, 5B, 5R	25	Rack-Out Assembly-Left	0209B3584G001
5A, 5B, 5R	25	Rack-Out Assembly-Right	0209B3584G002
5B, 5S	26	Redundant Negative Interlock Assembly	0177C2131G007
5A	27	Relay-Anti Pump	Table 5G
5B	28	Secondary Disconnect Assembly (Pin Connectors Not Included)	0209B3579G001
5A, 5U	29	Secondary Disconnect Handle	0209B35342G001
5V	30	Spline Adapter Assembly	0282A5219G001
5B, 5W	31	Spring Discharge Interlock Assembly	0177C2130G005
5A, 5B, 5X	32	Swivel Caster	0282A2406P002
5A	33	Trip Coil (potential)	Table 5E
5B	34	Trip Roller	0282A2000P200
NI	-	Undervoltage Trip Device (125 VDC)	0282A5218G002
NI	-	Undervoltage Trip Device (250VDC)	0282A5218G003
NI	-	Undervoltage Trip Device (48 VDC)	0282A5218G001

Medium Voltage Circuit Breaker/Switchgear Parts

For more information contact your authorized GE sales representative or GE distributor.

Courtesy of store.ips.us

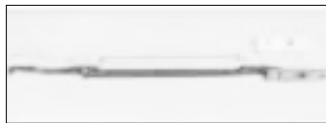

Rack-Out Arm Assembly
(Ref. 25)



Secondary Disconnect Handle
(Ref. 29)



Clutch Assembly for Motor
(Ref. 10)

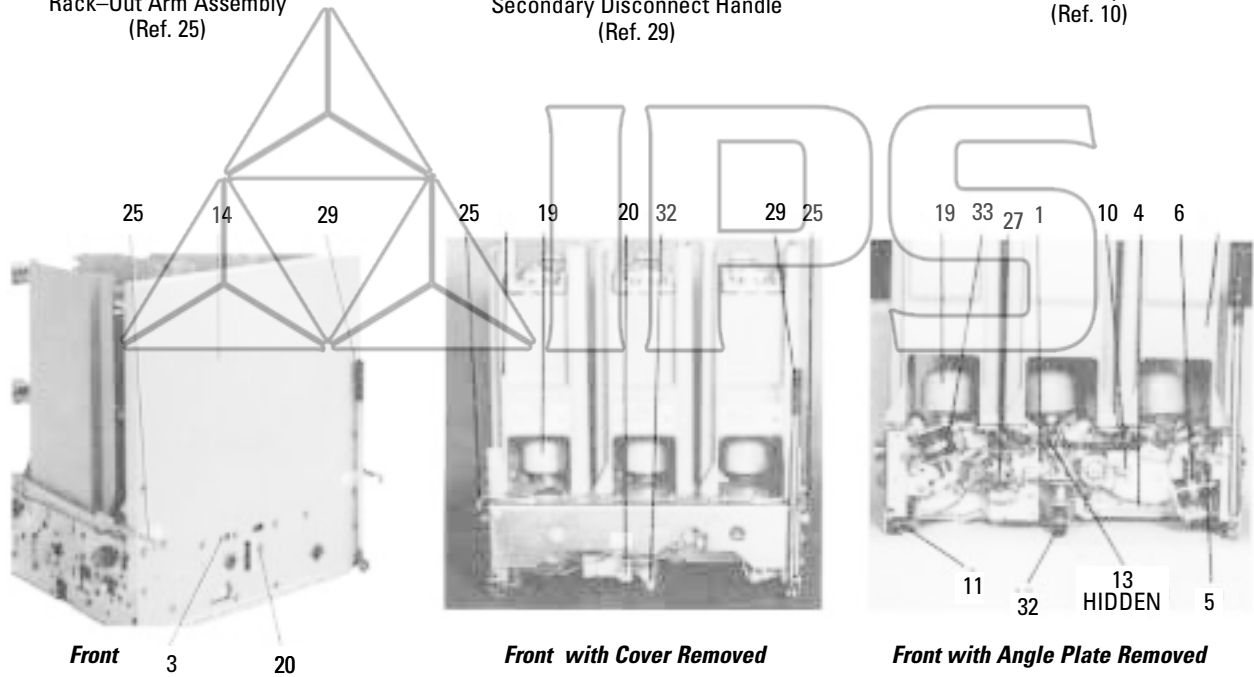

Medium Voltage Circuit Breaker/Switchgear Parts

store.ips.us



Charge-Discharge Flag
Operating Rod
(Ref. 3)



Operation Counter
(Ref. 20)



Swivel Caste
(Ref. 32)



Dash Pot Assembly
Ref. 13)

Figure 5A, PowerVac[®] Vacuum Circuit Breaker (Front Views)



GE Support Services

76 Medium Voltage Circuit Breaker/Switchgear Parts

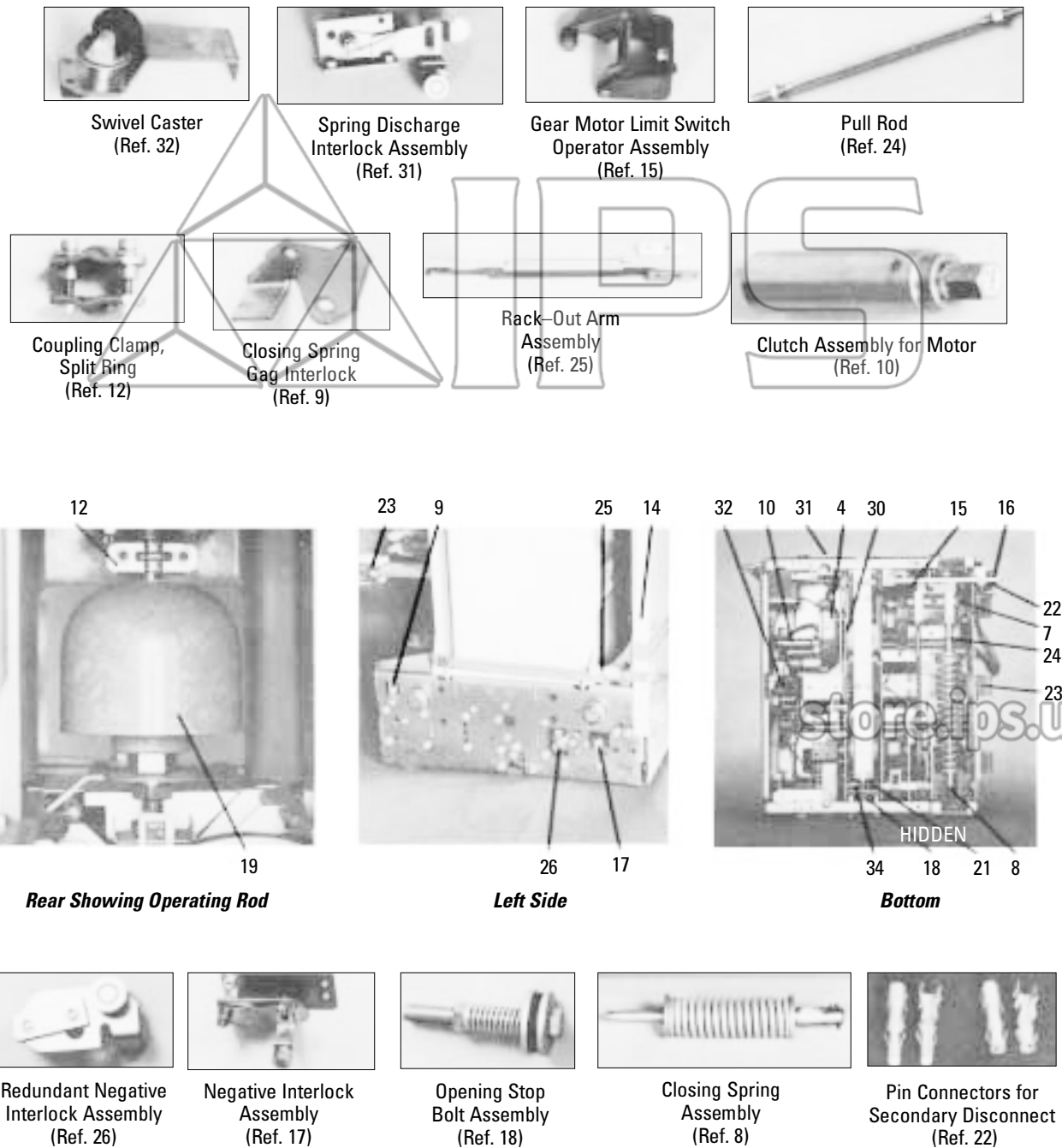

Figure 5B, PowerVac Vacuum Circuit Breaker (Other Views)

For more information contact your authorized GE sales representative or GE distributor.

Table 5B, Back View of Power Vac® Vacuum Circuit Breaker with ML-17 Trip Mechanism

Fig. No.	Ref. No.	Description	Catalog Number
5B	1	Auxiliary Switch (Model Designator 0)	0209B3410P002
5B	1	Auxiliary Switch (Model Designator 1,2,3)	0209B3410P001
5B	4	Charging Motor	Table 5C
5B	7	Closing Roller	0282S2000P100
5B	8	Closing Spring Assembly	0209B3526G002
5B	9	Closing Spring Gag Interlock	0282A2181P001
5B	10	Clutch Assembly for Motor (Model Designator 0,1,2)	0282A2402G001
5B	10	Clutch Assembly for Motor (Model Designator 3)	0282A2402G002
5B	12	Coupling Clamp, Split Ring	0282A5061G003
5B	14	Front Cover Assembly (Model Designator 0,1,2)	0209B3581G001
5B	14	Front Cover Assembly (Model Designator 3)	0209B3581G002
5B	15	Gear Motor Limit Switch Operator Assembly	0209B3626G001
5B	16	Ground Rod	0282A2147P001
5B	17	Negative Interlock Assembly	0177C2131G002
5B	18	Opening Stop Bolt Assembly	0282A5045G001
5B	19	Operating Rod	0209B3401G001
5B	21	Over Travel Stop Adjustment Bolt (2 1/8")	N176P2534B6
5B	21	Over Travel Stop Adjustment Bolt (2")	N176P2532B6
5B	22	Pin Connectors, Female (On Equipment)	0282A2081P002
5B	22	Pin Connectors, Male (On Breaker)	0282A2081P001
5B	23	Primary Disconnect	Table 5F
5B	24	Pull Rod (Model Designator 3)	0282A2476P002
5B	24	Pull Rod (Model Designator 0,1,2)	0282A2476P001
5B	25	Rack-Out Assembly – Left	0209B3584G001
5B	25	Rack-Out Assembly – Right	0209B2584G002
5B	26	Redundant Negative Interlock Assembly	0177C2131G007
5B	28	Secondary Disconnect Assembly (Pin Connectors Not Included)	0209B3579G001
5B	31	Spring Discharge Interlock Assembly	0177C2130G005
5B	32	Swivel Caster	0282A2406P002

Medium Voltage Circuit Breaker/Switchgear Parts

Table 5C, Charging Motor for ML-17 Trip Mechanism
 –See Figures 5A & 5B

Voltage	Model Designator	Catalog Number
48VDC	0, 1, 2	G004
120VAC		G002
125VDC		0282A5222
240VAC		G003
250VDC		G003
48VDC	3	G003
120VAC		G001
125VDC		0177C2164
240VAC		G002
250VDC		G002



GE Support Services

78 Medium Voltage Circuit Breaker/Switchgear Parts

Table 5D, Closing Coil for ML-17 Trip Mechanism – See Figure 5A

Breaker Close Voltage (V)	Fast Bus Transfer	Amps (A)	Range	Catalog Number	
48DC	No	9.6	38–56	0282A7340	P001
	Yes	N/A		N/A	
125DC	No	6.0	100–140	0282A2009	P002
	Yes	32.0			P005
250DC	No	3.0	200–280		P003
	Yes	12.0			P002
120AC	No	8.0	104–127	P004	
	Yes	N/A		N/A	
240AC	No	10.3	208–254	0282A2009	P005
	Yes	16.0		P004	

Table 5E, Trip Coil for ML-17 Trip Mechanism – See Figure 5A

Breaker Trip Voltage	Breaker Cycle	Volts	Amps (A)	Range	Catalog Number	
48VDC	5	48VDC	26	28–56	0282A2009	P007
	3		9.6			P001
125VDC	5	125VDC	10.2	70–140		P008
	3		6			P002
250VDC	5	250VDC	5.2	140–280		P009
	3		3			P003
240VAC	3 and 5	340VAC	2.3	295–360		P010

Medium Voltage Circuit Breaker/Switchgear Parts

For more information contact your authorized GE sales representative or GE distributor.

Table 5F, Primary Disconnects for ML-17 Trip Mechanism

Current Rating	MVA Rating	High Momentary	Catalog Number	
1200A	250	No	0282A2701	G001
		Yes		
	350	—	0282A2700	
	500 (13.8)	No	0282A2725	
		Yes	0282A2701	
	750	No	0282A2700	
Yes				
1000	1500	0209B4272	G002	
				1500
2000A	All Others	Furnished Elsewhere		
1200/2000A	1500	0282A2700	G001	
	All Others	0282A2702		
3000A	1500	0282A2702		
	All Others			

—Any legitimate alternative condition will suffice.

Medium Voltage Circuit Breaker/Switchgear Parts

Table 5G Relays (Anti-Pump) for ML-17 Trip Mechanism –See Figure 5A

Closing Voltage	Frequency	Catalog Number	
48VDC	—	0282A2008	P001
125VDC			P002
250VDC			G001
120VAC	60HZ		P003
	50HZ		P005
240VAC	60HZ		P004
	50HZ	P006	

—Any legitimate alternative condition will suffice.

store.ips.us



80 Medium Voltage Circuit Breaker/Switchgear Parts

Table 5-2, Power Vac® Vacuum Circuit Breaker with ML-18 Trip Mechanism

Fig. No.	Ref. No.	Description	Model Designator	Catalog Number
5AA, 5BB	1	Auxiliary Switch (Electroswitch) 10-a's & 10-b's	PVDB 1, 2	0209B5164G001
5AA, 5BB	1	Auxiliary Switch (Electroswitch) 3-a's & 3-b's	PVDB 1, 2	0209B5165P001
5AA, 5BB	1	Auxiliary Switch (Electroswitch) 4-a's & 4-b's	VB-1 1,2,3 & PVDB 1,2	0209B4825P001
5AA, 5BB	1	Auxiliary Switch (Electroswitch) 5-a's & 5-b's	VB-1 1,2,3 & PVDB 1,2	0209B4826P001
5AA, 5BB	1	Auxiliary Switch (Electroswitch) 6-a's & 6-b's	PVDB 1, 2	0209B5163P001
5BB	2	Auxiliary Switch Mounting - (Single) 3 or 6-a's & 3 or 6-b's	PVDB 1, 2	0144D1516G002
5BB	2	Auxiliary Switch Mounting - (Tandem) 10-a's & 10-b's	PVDB 1, 2	0144D1516G003
NI	-	Bushing Grounding Spring (1200A)	PVDB 0 1, 2	0282A6496G001
NI	-	Bushing Grounding Spring (2000A)	PVDB 0 1, 2	0282A6496G002
5AA	3	Caster Wheel & Bracket	VB-1 0,1,2,3	0282B8085G001
5AA	4	Charging Link Assembly	VB-1 0,1,2,3 & PVDB 0,1,2	0209B8041G001
5AA	5	Charging Motor	VB-1 0,1,2,3 & PVDB 0,1,2	Table 5AA
5AA	6	Charging Ratchet	VB-1 0,1,2,3 & PVDB 0,1,2	0209B8034G001
5CC	7	Close Cam	VB-1 0,1,2,3 & PVDB 0,1,2	0144D1229P001
5AA	8	Close Latch	VB-1 0,1 & PVDB 0	0282A7244G001
5AA	9	Close Latch Pin ##	VB-1 2,3 & PVDB 1,2	0209B3894P001
5AA	9	Close Latch Pin for Replacement ##	VB-1 2 & PVDB 1	0209B8075P001
5AA	9	Close Latch Pin for Replacement ##	VB-1 3 & PVDB 2	0209B8075P003
5AA	10	Close Shaft \$\$	VB-1 0,1, & PVDB 0	0209B8009P001
5AA	10	Close Shaft \$\$	VB-1 2,3 & PVDB 1,2	0209B8111P001
5AA	11	Close Spring Crank @@, \$\$	VB-1 0,1 & PVDB 0	0209B8000P001
5AA	11	Close Spring Crank @@, \$\$	VB-1 2,3 & PVDB 1,2	0209B8000P002
5A	12	Closing Coil		Table 5BB
5AA	13	Closing Spring & Guide Assembly	VB-1 0,1,2,3	0282A7311G001
5AA	13	Closing Spring & Guide Assembly	PVDB 0,1,2	0282A7311G002
NI	-	Closing Spring Gag Plate	VB-1 0,1,2,3 & PVDB 0,1,2	0209B8043G001
NI	-	Closing Spring Gag Plate	VB-1 0,1,2,3 & PVDB 0,1,2	0209B8043G002
NI	-	Compartment Heater Mounting - 2 Heaters	PVDB 0 1, 2	0282A6519G001
NI	-	Compartment Heater Mounting - 4 heaters	PVDB 0 1, 2	0282A6519G002
5DD	14	Control Switch, Normally Closed	VB-1 0,1,2,3 & PVDB 0,1,2	0282A2097P002
5DD	14	Control Switch, Normally Open	VB-1 0,1,2,3 & PVDB 0,1,2	0282A2097P001
5DD	14	Control Switch, Normally Open (52/CLMS)	VB-1 0,1,2,3 & PVDB 0,1,2	0282A2097P003
NI	-	Door Latch Parts	PVDB 0 1, 2	0282A6557G002
5EE	15	Erosion Disk	VB-1 0,1,2,3 & PVDB 0,1,2	0282A7196G001
NI	-	Erosion Disk Indicator	VB-1 0,1,2,3 & PVDB 0,1,2	0282A7195P001
NI	-	External Trip Assembly Parts	PVDB 0 1, 2	0282A6557G001
NI	-	Fastener Assortment ("X" washer)	VB-1 0,1,2,3 & PVDB 0,1,2	0282A20115G001
5AA	16	Ground Bus Bar	VB-1 0,1,2,3	0282A2149P001
5AA	17	Interrupter Clamp	VB-1 0,1,2,3 & PVDB 0,1,2	0282A5061G003
NI	-	Lifting Bracket	VB-1 0,1,2,3	0209B6588G001
NI	-	Lubricating Grease	VB-1 0,1,2,3 & PVDB 0,1,2	0282A2048P012
NI	-	Manual Charge Handle	VB-1 0,1,2,3 & PVDB 0,1,2	0282A7227P001
NI	-	Mechanism Removal Bracket	PVDB 0	0209B6539G001
5AA, 5FF	18	Negative Interlock	VB-1 0,1,2,3	0177C5007G002
5AA	19	Opening Spring	VB-1 0,1,2,3	0282A7043P001

To Replace Close Latch #0282A7244G001, Order 1 - 0209B8075P003 & 1 - 0209B3894P001

@@ 0209B1111P001 Replaces 0209B8009P001

\$\$ Reference Part Numbers 10, 11, & 25 Must be Replaced as Set for VB-1 0, 1 & PVDB 0 Models

For more information contact your authorized GE sales representative or GE distributor.

Table 5-2, Power Vac® Vacuum Circuit Breaker with ML-18 Trip Mechanism

Fig. No.	Ref. No.	Description	Model Designator	Catalog Number
5AA	20	Opening Spring Rod	VB-1 0,1,2,3 & PVDB 0,1,2	0282A7128G001
5EE	21	Operating Rod	VB-1 0,1,2,3 & PVDB 0,1,2	0177C5014G001
5GG	22	Operation Counter	VB-1 0,1,2,3 & PVDB 0,1,2	0282A7168P001
NI	-	Operation Counter Spring	VB-1 0,1,2,3 & PVDB 0,1,2	0282A7138P001
NI	-	Pin Retainer Assortment (Snap & "C" Rings)	VB-1 0,1,2,3 & PVDB 0,1,2	0282A5293G001
5AA	23	Positive Interlock	VB-1 0,1,2,3	0209B8040G001
5GG	24	Primary Disconnect	VB-1 0,1,2,3	Table 5GG
5AA	25	Prop Latch	VB-1 0,1,2,3 & PVDB 0,1,2	0282A7165G001
5DD	26	Relay - Anti Pump	VB-1 0,1,2,3 & PVDB 0,1,2	Table 5FF
NI	-	Roof Bushing Assembly (1200A)	PVDB 0 1, 2	0177C6626G001
NI	-	Roof Bushing Assembly (2000A)	PVDB 0 1, 2	0177C6628G001
5GG	27	Secondary Disconnect Assembly	VB-1 0,1,2,3	0209B3579G001
5GG	27	Secondary Disconnect Male Pins	VB-1 0,1,2,3	0282A2081P001
NI	-	Spring Assortment	VB-1 0,1,2,3 & PVDB 0,1,2	0282A6558G001
5GG	28	Spring Discharge Interlock	VB-1 0,1,2,3	0209B8032G001
5AA	29	Stop for Center Phase Vacuum Interrupter	VB-1 1,2,3 & PVDB 1,2	0177C6640G001
5AA	29	Stop for Center Phase Vacuum Interrupter	VB-1 0	0282A7143G001
NI	-	Strip Heater (300W/240V)	PVDB 0 1, 2	0282A4386P001
NI	-	Test Coupler	VB-1 0,1,2,3	0177C3943G001
5CC	30	Toggle Linkage Assembly %%	VB-1 0,1 & PVDB 0	0209B8102G001
5CC	30	Toggle Linkage Assembly %%	VB-1 2,3 & PVDB 1,2	0209B8102G002
5FF, 5GG	31	Track Rollers	VB-1 0,1,2,3	0282A2464G001
NI	-	Travel Recorder Parts	VB-1 0,1,2,3 & PVDB 0,1,2	0144D1235G001
5AA	32	Trip Coil (potential)		Table 5CC
5AA	33	Trip Latch	VB-1 0,1,2,3 & PVDB 0,1,2	0282A7147P001
5EE	34	Wipe String Assembly	VB-1 0,1,2,3 & PVDB 0,1,2	0209B8072G002

Medium Voltage Circuit Breaker/Switchgear Parts

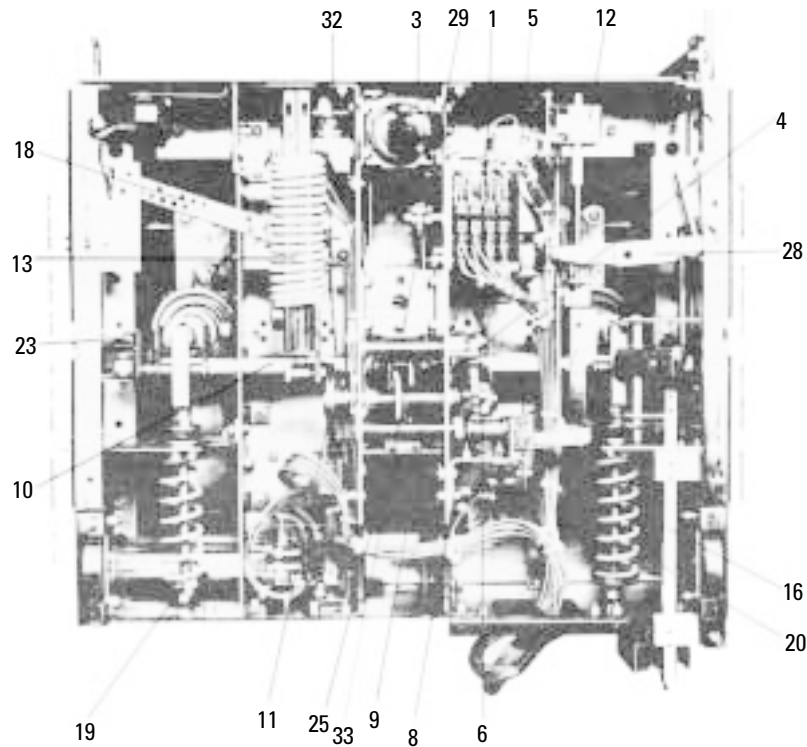

Figure 5AA: Bottom View



GE Support Services

Table 5AA, Charging Motor for ML-18 Trip Mechanism – See Figure 5AA

Voltage	Model Designator	Catalog Number		
48VDC	--	0177C5050	G004	120VAC 125VDC
120VAC			G002	Use 0177C5050G005
125VDC			G002	250VDC 230VAC
240VAC			G003	Use 0177C5050G006
250VDC			G003	48VDC

--All that apply.

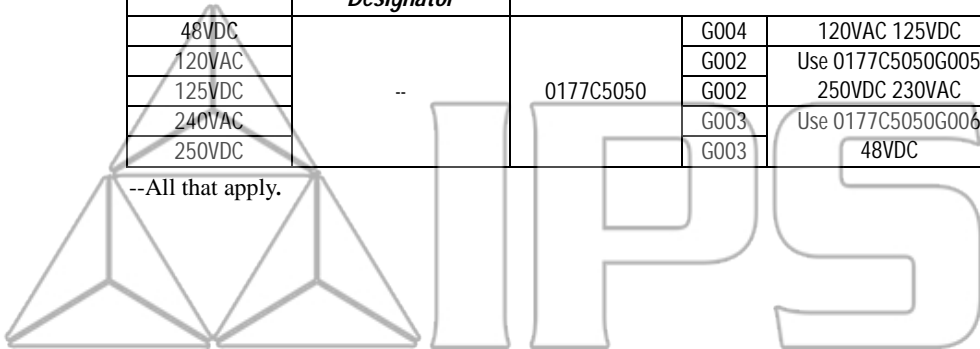

Table 5BB, Close Coil for ML –18 Trip Mechanism –See Figure 5AA

Breaker Close Voltage (V)	Fast Bus Transfer	Amps (A)	Range	Catalog Number	
48DC	No	13.7	38-56	0282A7340	G004
	Yes	N/A		N/A	
125DC	No	6.0	100-140	0282A7340	G002
	Yes	35.7			G001
250DC	No	2.8	200-280		G003
	Yes	12.0			G002
120AC	No	6.0	104-127	N/A	
	Yes	N/A		N/A	
240AC	No	2.8	208-254	0282A7340	G005
	Yes	N/A		N/A	

Table 5CC, Trip Coil for ML-18 Trip Mechanism – See Figure 5AA

Mech Trip Voltage	Breaker Cycle	Volts	Amps (A)	Range	Catalog Number	
48VDC	5	48VDC	22A	28-56	0282A7015	G004
	3					G006
125VDC	5	125VDC	7.3A	70-140		G011
	3		10.5A			G007
250VDC	5	250VDC	4.7A	140-280		G010
	3		10.8A			G009
240VAC	5	340VAC	3.7A	295-360		G010
	3		14.7A			

For more information contact your authorized GE sales representative or GE distributor

Medium Voltage Circuit Breaker/Switchgear Parts

Table 5DD, Bottom View of Power Vac® Vacuum Circuit Breaker with ML-18 Trip Mechanism

Fig. No.	Ref. No.	Description	Model Designator	Catalog Number
5BB	1	Auxiliary Switch (Electroswitch) 10-a's & 10-b's	PVDB 1, 2	0209B5164G001
5BB	1	Auxiliary Switch (Electroswitch) 3-a's & 3-b's	PVDB 1, 2	0209B5165P001
5BB	1	Auxiliary Switch (Electroswitch) 4-a's & 4-b's	VB-1 1,2,3 & PVDB 1,2	0209B4825P001
5BB	1	Auxiliary Switch (Electroswitch) 5-a's & 5-b's	VB-1 1,2,3 & PVDB 1,2	0209B4826P001
5BB	1	Auxiliary Switch (Electroswitch) 6-a's & 6-b's	PVDB 1, 2	0209B5163P001
5BB	2	Auxiliary Switch Mounting-(Single) 3 or 6-a's & 3 or 6-b's	PVDB 1, 2	0144D1516G002
5BB	2	Auxiliary Switch Mounting-(Tandem) 10-a's & 10-b's	PVDB 1, 2	0144D1516G003
5CC	7	Close Cam	VB-1 0,1,2,3 & PVDB 0,1,2	0144D1229P001
5CC	30	Toggle Linkage Assembly	VB-1 0,1 & PVDB 0	0209B8102G001
5CC	30	Toggle Linkage Assembly	VB-1 2,3 & PVDB 1,2	0209B8102G002

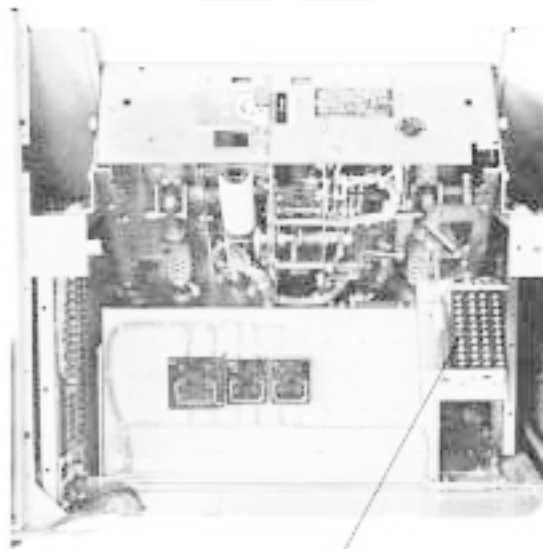

1, 2

Figure 5BB: PVDB Mechanism Compartment View

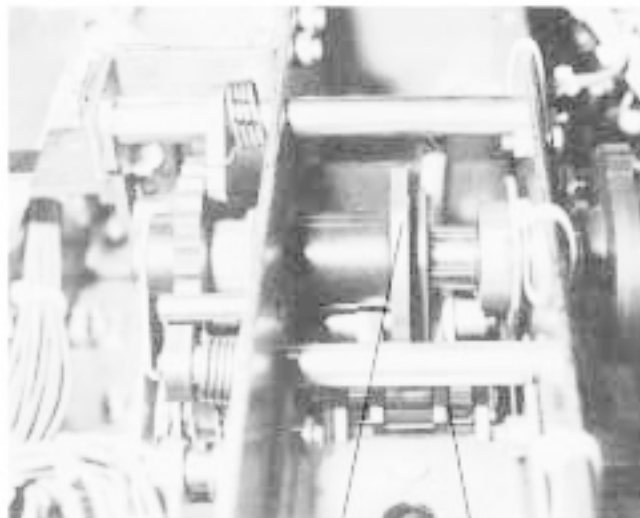

7 30

Figure 5CC: Bottom View

Medium Voltage Circuit Breaker/Switchgear Parts

store.ips.us



GE Support Services

Table 5EE, Bottom View of Power Vac® Vacuum Circuit Breaker with ML-18 Trip Mechanism

Fig. No.	Ref. No.	Description	Model Designator	Catalog Number
5DD	14	Control Switch, Normally Closed	VB-1 0,1,2,3 & PVDB 0,1,2	0282A2097P002
5DD	14	Control Switch, Normally Open	VB-1 0,1,2,3 & PVDB 0,1,2	0282A2097P001
5DD	14	Control Switch, Normally Open (52/CLMS)	VB-1 0,1,2,3 & PVDB 0,1,2	0282A2097P003
5DD	26	Relay – Anti Pump	VB-1 0,1,2,3 & PVDB 0,1,2	Table 5FF
5EE	15	Erosion Disk	VB-1 0,1,2,3 & PVDB 0,1,2	0282A7196G001
5EE	21	Operating Rod	VB-1 0,1,2,3 & PVDB 0,1,2	0177C5014G001
5EE	34	Wipe Spring Assembly	VB-1 0,1,2,3 & PVDB 0,1,2	0209B8072G002
5FF	31	Track Rollers	VB-1 0,1,2,3	0282A2464G001
5GG	22	Operation Counter	VB-1 0,1,2,3 & PVDB 0,1,2	0282A7168P001
5GG	24	Primary Disconnect	VB-1 0,1,2,3	Table 5GG
5GG	27	Secondary Disconnect Assembly	VB-1 0,1,2,3	0209B3579G001
5GG	27	Secondary Disconnect Male Pins	VB-1 0,1,2,3	0282A2081P001
5GG	28	Spring Discharge Interlock	VB-1 0,1,2,3	0209B8032G001
5GG	31	Track Rollers	VB-1 0,1,2,3	0282A2464G001



Figure 5DD, Bottom View

**Table 5FF, Relays (Anti-Pump)
– See Figure 5DD**

Closing Voltage	Catalog Number
48VDC	P001
125VDC	P002
250VDC	G001
120VAC	P003
240VAC	P004

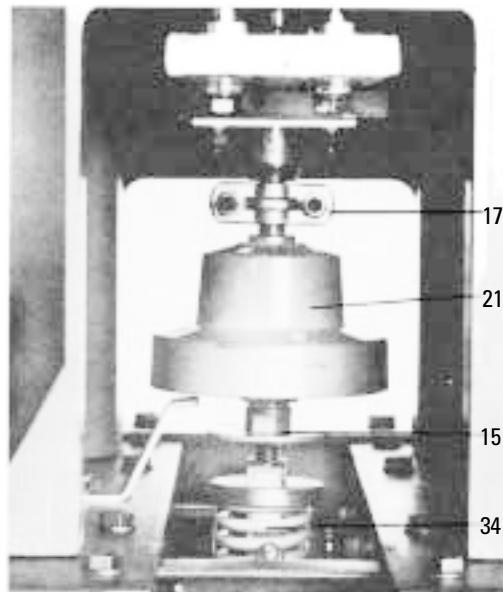

Figure 5EE, Operating Rod & Wipe Spring

For more information contact your authorized GE sales representative or GE distributor.

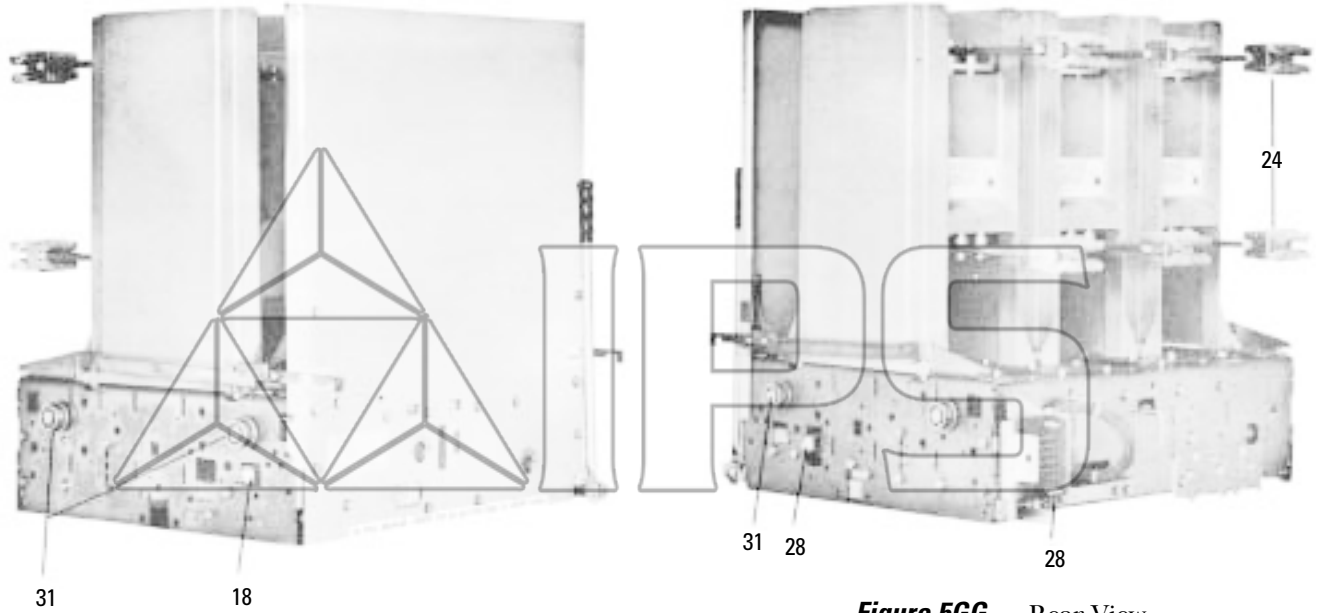

Figure 5FF, Front and Side View

Figure 5GG, Rear View

Medium Voltage Circuit Breaker/Switchgear Parts

Table 5GG, Primary Disconnects for ML-18 Trip Mechanism –See Figure 5GG

Current Rating	MVA Rating	High Momentary	Catalog Number	
1200A	250	No	0282A2701	G001
		Yes		
	350	—	0282A2700	
	500 (7.2)			
	500 (13.8)	No	0282A2725	
	750	Yes	0282A2701	
		No		
Yes				
1000	1500	—	0282A2700	
			0209B4272	
2000A	1500	—	0282A2700	G002
1200/2000A	All Others		Furnished Elsewhere	
3000A	1500	—	0282A7597	G001
	All Others		0282A2702	

—Any legitimate alternative condition will suffice.



GE Support Services

Table 5-3, Power/Vac Equipment & Cubicle Parts for ML-17 and ML-18 Trip Mechanisms

Description	Catalog Number	Description	Catalog Number
#6 S/S Cable Terminal	21675037500	Interlock Mod. Kit (<i>note: order G3 and 4 guages also</i>)	0282A5286G002
2 Pole 30A Fuse Block (Not UL Listed)	0673D0515421G001	JKS-CT Mtg Asm (Left)	0282A3124G001
2 Pole 60A Fuse Block (Not UL Listed)	0673D0515422G001	JKS - CT Mtg Asm (Right)	0282A3124G002
3000A Springs used in Primary Finger Assembly	0282A2053P001	Left Hand Storage Rail	0177C3702G013
Armor Sheilded Wire #10	LW8967-A	Left Hand Track Asm.	0177C3702G001
Armor Sheilded Wire #12	LW8302	Manual Close Button Field Mod. Kit.	0177C3731G001
Armor Sheilded Wire #14	LW8301	ML-18 Charging Handle	0282A7227P001
Barrier in Front of Shutter	0177C3643P001	ML-18 Gag Plate	0209B8043G001
Barrier-New Breakers in Old Equip.	0282A3750G001	Piano Hinge 45"	0282A3510P001
Blank Interference Plates	0209B3546P001	Piggy Back Bolt for CTs	0282A4015P001
Bolt Ins	0177C3936G001	Pin Kit for Door	0177C3920G002
Boot Glue Can	0282A3566P001	Plastic Coupler Block (Female)	0209B3403P001
Cal Code Barrier	0144D2421P001	Plastic Coupler Block (Male)	0209B3402P001
Coffin Door Hinges	0209B4667G001	Porcelain Sleeve (All Ratings)	0177C3201P001
Copper Bus Bar-3/8" x 6" x 34"	0282A3410P002	Porcelain Stadoff Insulators 30	0177C3406G004
CT Mtg Angles	0235B5314G001	Porcelain Standoff Insulators 12/20	0177C3406G003
CT Mtg Hardware Doubles (Doughnut)	0209B5010G002	Porcelain Tube for Cable	0227A5914P001
CT Mtg Hardware Singles (Doughnut)	0209B5010G001	Right Hand Storage Rail	0177C3702G014
Door Bolt	0282A4144P001	Right Hand Track Asm.	0177C3702G002
Door Gasket	21450009000	Racking Mod. Kit	0209B8107G001
Door Stop Assembly	0209B4064G001	Rear Side Panels (94")	0144D2403P001
Filter Pad	0137A9572P001	Remote Racking Operator (Field Kit)	0177C3920G001
Front Covers-Indoor (A-Compt)	0177C3023G001	Rotating Breaker Maintenance Table	0154D6766G001
Front Covers-Indoor (B-Compt)	0177C3023G002	Secondary Disc. for Rollouts (Moveable)	0209B4493G001
GE PV on Pub Stripe	0282A2002P001	Secondary Disc. for Rollouts (Stationary)	0209B4495G001
Grading Shield	0209B4066P001	Secondary Disc. Coupler Asm (A) (Equip)	0209B4052G002
Grd Bus Asm.	0177C3301G002	Secondary Disc. Coupler Asm (B) (Equip)	0209B4052G003
Grd Shoe Asm. Equip	0209B4055G001	Shutter Assembly (Std)	0144D2125G003
GSCT Mounting Kit (12" D. Window)	0235B5313G001	Shutter Assembly (Non-Conducting)	0144D2125G004
GSCT Mounting Kit (7 1/4" D. Window)	0177C3606G008	Special Keylock Rail L.H. Racking Mechanism	0144D2113G004
Heater Mountig Asm. w/out Heater	0282A3116P001	Stationary Breaker Maintenance Table	0154D6759G001
Ind Tape Roller Asm.	0282A4307G001	Std Keylock Mounting Bracket	0209B5078G001
Indicating Tape	0282A3522P001	Spreader Bar and Chain	0177C3225G001
Interference Plate Supt	0209B4034G001	Test Coupler	0177C3943G001
Interlock Mod. Kit	0282A5286G001	Vent Trough Angle Brackets	0209B4343G001

Medium Voltage Circuit Breaker/Switchgear Parts

For more information contact your authorized GE sales representative or GE distributor.

Courtesy of store.ips.us

Magne Blast (Type AM) and GE/Vac Circuit Breaker

Included in this Section

The AM or GE/Vac Circuit Breaker is the removable and interchangeable interrupting element for use in Switchgear Equipment.

AM 4.16-250-6, -7, -8, -9
 AM 4.16-350-1
 AM 4.16-350-2

AM 7.2-500-6
 AM 13.8-500-5, -6
 AM 13.8-750-4
 AM 13.8-750-5, -6

AM 13.8-1000-3
 AM 13.8-1000-4
 GE/Vac-All Ratings

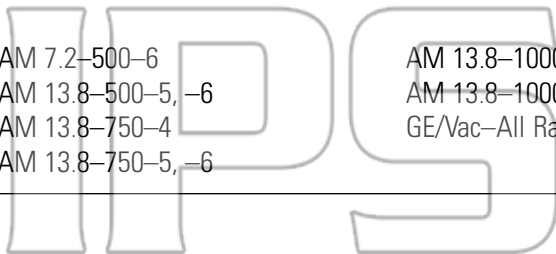
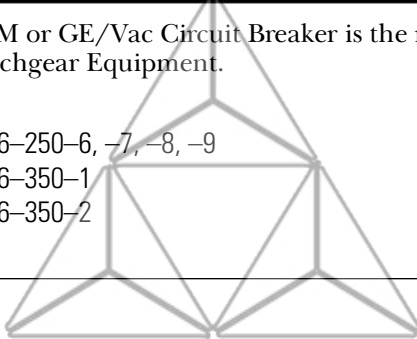

Medium Voltage Circuit Breaker/Switchgear Parts

Equipment Identification and Nomenclature Guide

- Furnish the complete nameplate data of circuit breaker for identification purposes.
- Specify quantity, catalog number, item number, and description for each part.
- Breaker Nameplate is located behind door.
- For pricing, proper installation and maintenance instructions, contact your local GE sales and/or service representative

Example: **AM-4.16-250-6H**



store.ips.us

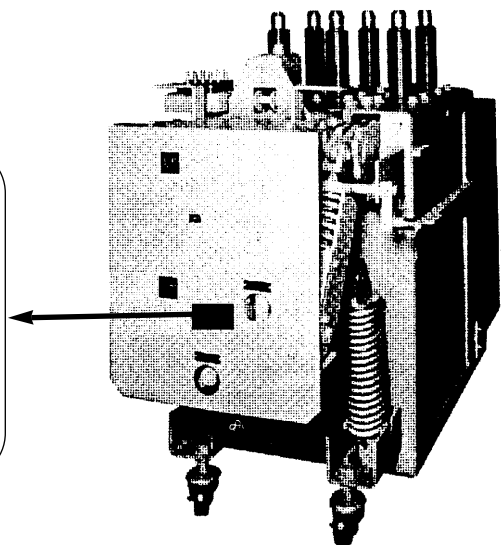
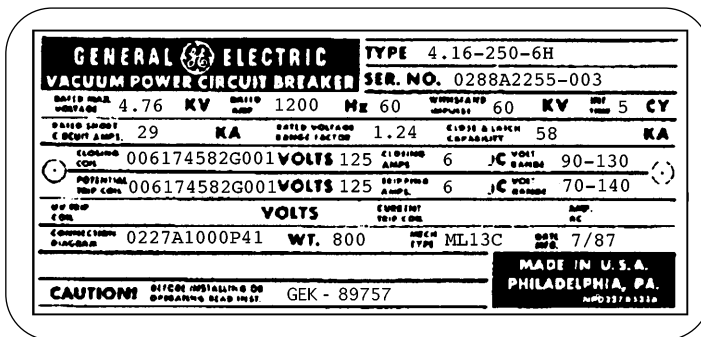

Figure 6, Magne Blast (Type AM) and GE/Vac Circuit Breaker Nameplate Data



GE Support Services

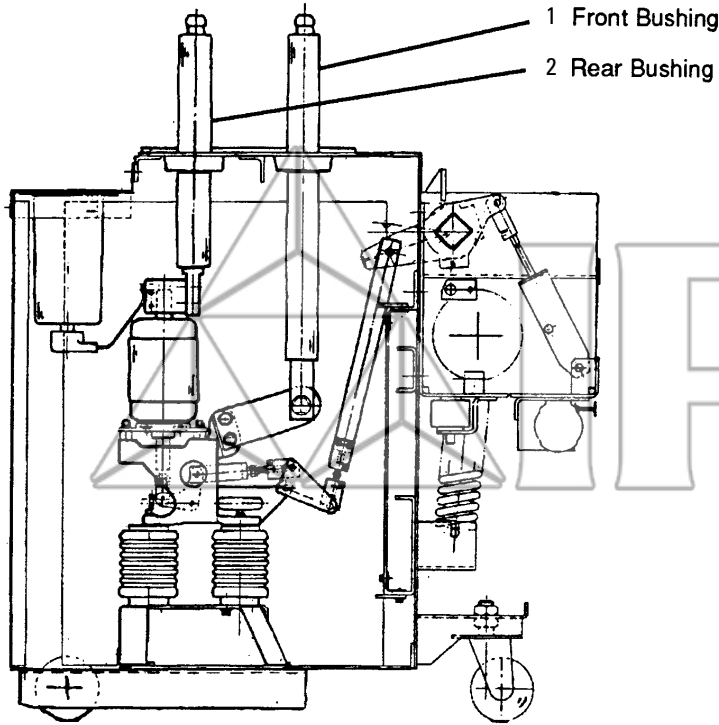

Figure 6A, GE/Vac® Circuit Breaker Front & Rear Bushings

Table 6A, GE/Vac® Circuit Breaker Front/Rear Bushings

–See Figure 6A above

Breaker Rating	Front	Rear
VVC 4.16–250–0–1200A	0845D0123G001	0845D0124G001
VVC 4.16–250–0–2000A	0688C0515G001	0688C0516G006
VVC 4.16–250–1–1200A	0845D0123G001	0845D0124G001
VVC 4.16–250–1–2000A	0688C0515G001	0688C0516G006
VVC 7.2–500–0–1200A	0845D0123G003	0845D0124G003
VVC 7.2–500–0–2000A	0958C0683G003	0958C0684G005
VVC 7.2–500–1–1200A	0845D0123G003	0845D0124G003
VVC 7.2–500–1–2000A	0958C0683G003	0958C0684G005
VVC 13.8–500–0–1200A	0845D0123G003	0845G0124G003
VVC 13.8–500–0–2000A	0958C0683G003	0958C0684G005
VVC 13.8–500–1–1200A	0845D0123G003	0845D0124G003
VVC 13.8–500–1–2000A	0958C0683G003	0958C0684G005
VVC 13.8–750–0–1200A	0845D0123G003	0845D0124G003
VVC 13.8–750–0–2000A	0958C0683G003	0958C0684G005
VVC 13.8–750–0L–1200A	0845D0123G004	0845D0124G007
VVC 13.8–750–0L–2000A	0265C0188G007	0132C2725G001
VVC 13.8–750–1–1200A	0845D0123G003	0845D0124G003
VVC 13.8–750–1–2000A	0958C0683G003	0958C0684G005
VVC 13.8–750–1L–1200A	0845D0123G004	0845D0124G007
VVC 13.8–750–1L–2000A	0265C0188G007	0132C2725G001
VVC 13.8–1000–0–1200A	0845D0123G004	0845G0124G007
VVC 13.8–1000–0–2000A	0265C0188G007	0132C2725G001
VVC 13.8–1000–0–3000A	0172C7638G002	0172C7638G001
VVC 13.8–1000–1–1200A	0845D0123G004	0845D0124G007
VVC 13.8–1000–1–2000A	0265C0188G007	0132C2725G001
VVC 13.8–1000–1–3000A	0172C7638G002	0172C7638G001

store.ips.us

For more information contact your authorized GE sales representative or GE distributor.

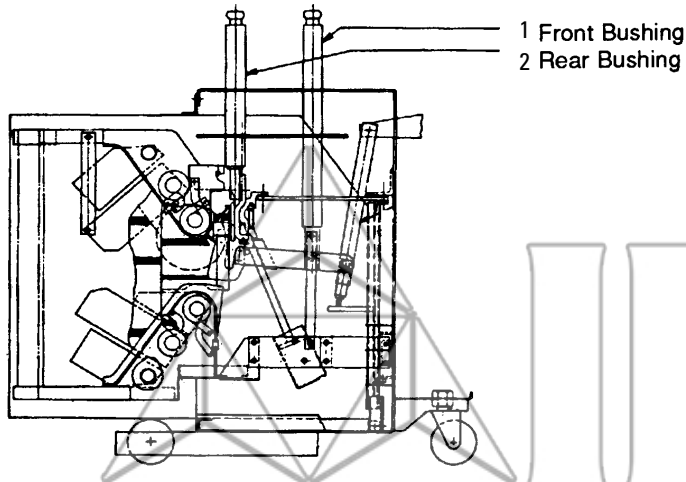

Figure 6B, Magne-Blast® Circuit Breaker Front & Rear Bushings

Table 6B, Magne-Blast Circuit Breaker Front/Rear Bushings
 –See Figure 6B above

Breaker Rating	Front	Rear
AM 4.16-250-6-1200A	0845D0123G001	0845D0124G001
AM 4.16-250-6-2000A	0688C0515G001	0688C0516G001
AM 4.16-250-7-1200A	0845D0123G001	0845D0123G001
AM 4.16-250-7-2000A	0688C0515G001	0688C0516G006
AM 4.16-250-8-1200A	0845D0123G001	0845D0124G001
AM 4.16-250-8-2000A	0688C0515G001	0688C0516G006
AM 4.16-250-9-1200A	0845D0123G001	0845D0124G001
AM 4.16-250-9-2000A	0688C0515G001	0688C0516G006
AM 4.16-350-1-1200A	0845D0123G002	0845D0124G002
AM 4.16-350-1-2000A	0688C0515G005	0688C0515G007
AM 4.16-350-1-3000A	0619C0438G002	0619C0438G001
AM 4.16-350-2-1200A	0845D0123G002	0845D0124G006
AM 4.16-350-2-2000A	0688C0515C005	0688C0516G008
AM 4.16-350-2-3000A	0619C0438G002	0619C0438G001
AM 7.2-500-6-1200A	0845D0123G003	0845D0124G003
AM 7.2-500-6-2000A	0958C0683G003	0958C0684G005
AM 13.8-500-5-1200A	0845D0123G003	0845D0124G003
AM 13.8-500-5-2000A	0958C0683G003	0958C0684G003
AM 13.8-500-6-1200A	0845D0123G003	0845D0124G003
AM 13.8-500-6-2000A	0958C0683G003	0958C0684G005
AM 13.8-500-7-1200A	0845D0123G003	0845D0124G003
AM 13.8-500-7-2000A	0958C0683G003	0958C0684G005
AM 13.8-750-4-1200A	0845D0123G004	0845D0123G007
AM 13.8-750-4-2000A	0265C0188G007	0132C2725G001
AM 13.8-750-5-1200A	0845D0123G003	0845D0124G003
AM 13.8-750-5-2000A	0958C0683G003	0958C0684G005
AM 13.8-750-6-1200A	0845D0123G003	0845D0124G003
AM 13.8-750-6-2000A	0958C0683G003	0958C0684G005
AM 13.8-1000-3-1200A	0845D0123G005	0845D0124G005
AM 13.8-1000-3-2000A	0958C0683G003	0958C0684G003
AM 13.8-1000-3-3000A	0688C0514G002	0688C0514G001
AM 13.8-1000-4-1200A	0845D0123G004	0845D0124G007
AM 13.8-1000-4-2000A	0265C0188G007	0132C2725G001
AM 13.8-1000-4-3000A	0688C0514G006	0688C0514G005

store.ips.us

Medium Voltage Circuit Breaker/Switchgear Parts



GE Support Services

Table 6C, Coils

Closing Coils	Part Number
48DC	006174582G034
110/125DC	006174582G001
220DC	006174582G015
250DC	006174582G002
115AC	006174582G010
230AC	006174582G014
Tripping Coils	Part Number
24DC	006275070G001
32DC	006275070G003
48DC	006174582G034
125DC	006174582G001
220DC	006174582G015
250DC	006174582G002
115AC	006174582G013
230AC	006174582G032
Current Trip Coil (3AMP)	Part Number
	006174599G002
Undervoltage Coils	Part Number
115AC	006275017G016
230AC	006275017G012
48DC	006275017G045
125DC	006275017G015
250DC	003241202P001

Table 6D, Switches and Relays

Auxiliary Switch	Part Number
All Ratings	0137A9192R011
Micro Switches	Part Number
Normally Open	0456A0866P005
Normally Closed	0456A0866P006
Operation Counters	Part Number
Size	
Standard (All)	0161A5802R001
Large (All)	0114C5316G001
Relays Closing Voltage	Part Number
48DC	0137A7575P004
110DC	0137A7575P001
125DC	0137A7575P001
220DC	0108B5565R004
250DC	0108B5565R004
115AC 60HZ	0137A7575P005
230AC 60HZ	0137A7575P002
230AC 50HZ	0137A7575P009

Table 6E, Mechanism Bearing Kits

Type Mechanism	Part Number
ML-13	0156C9403G001
MS-13	0172C7847G001
ML-11	0172C7848G001
ML-12	0172C7849G001

Table 6F, Charging Motors

Voltage	Part Number
48VDC	0184B7360G001
115V/AC/125VDC	0184B7360G002
230V/AC/250VDC	0184B7360G003
230VAC	0184B7360G003

Table 6G, Current Trip Undervoltage Device

Description	Part Number
Current Trip Coil	006174599G002
Cutoff SW, AC	006275259R001
Cutoff SW, DC	006275259R002
Spring Release	
Crank 4.16, 250 & 350 MVA	0114C5343G002
Crank All 7.2 & 13.8	0114C5343G003
Plunger Interlock	
Complete Assembly	0105C9305R001
Secondary Disconnect (Male)	
Complete Assembly	0108B1931R005
Contact Pin	006319964P002
Contact Base	006505244P001
Secondary Disconnect (Female)	
Solenoid Mechanism	0237C0473G010
ML-13 Mechanism	0237C0473G011

For more information contact your authorized GE sales representative or GE distributor.

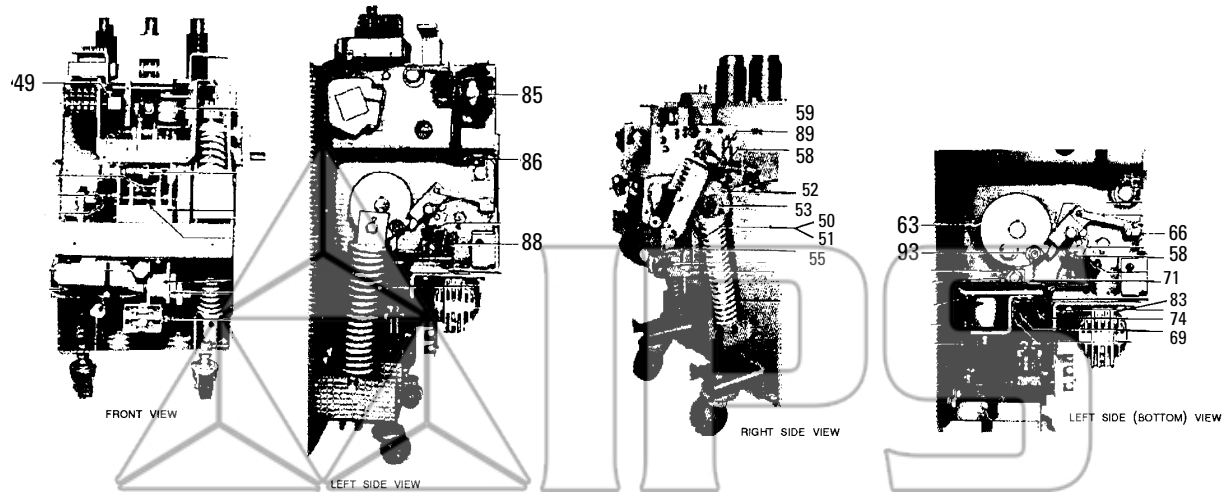

Figure 6C, ML-13 Mechanism Renewal Parts

Table 6H, ML-13 Mechanism Renewal Parts

–See Figure 6C above

Description	Part Number	Ref. No.
Indicator (Open/Close)	0105C9308G002	49
Indicator (Chg/Dis)	0105C9306G002	66
Pawl (Driving)	0213X0702G016	50
Pawl Spring	0161A4241P001	51
Ratchen Wheel	0105C9310G002	52
Bearing Block	0213X0702G022	53
Crank	0257A6975G001	55
Pawl (Outside)	0213X0702R014	58
Pawl (Inside)	0213X0702R015	59
Cam	0105C9311G002	63
Switch (N.C.)	0456A0866P006	88
Switch (N.O.)	0456A0866P005	69
Latch (Closing)	0114C5342G001	71
Clos. Latch Spring	0161A4231P001	74
Motor Mount	0105C9313G001	83
Auxiliary Switch	0137A9192R011	85
Latch CK. Switch	0161A4282R001	86
Pawl Spring	0161A5909P001	89
Cl.. Latch Roller	0414A0112P058	93
Prop Spring	0275A7211P001	15
Prop Spring #2 All VVC & All Magne-Blast with Dual Springs	006071231P001	16
Trip Latch Spring	0137A9262P001	19
Reset Spring	0137A9261P001	20
Closing Latch Spring–All Bkrs.before 1980	0161A4231P001	74
Closing Latch Spring–All Bkrs. after 1980	0257A6973P001	17
Driving Pawl Spring	0161A4241P001	51
Pawl Spring	0161A5909P001	89

store.ips.us



92 Medium Voltage Circuit Breaker/Switchgear Parts

Medium Voltage Circuit Breaker/Switchgear Parts

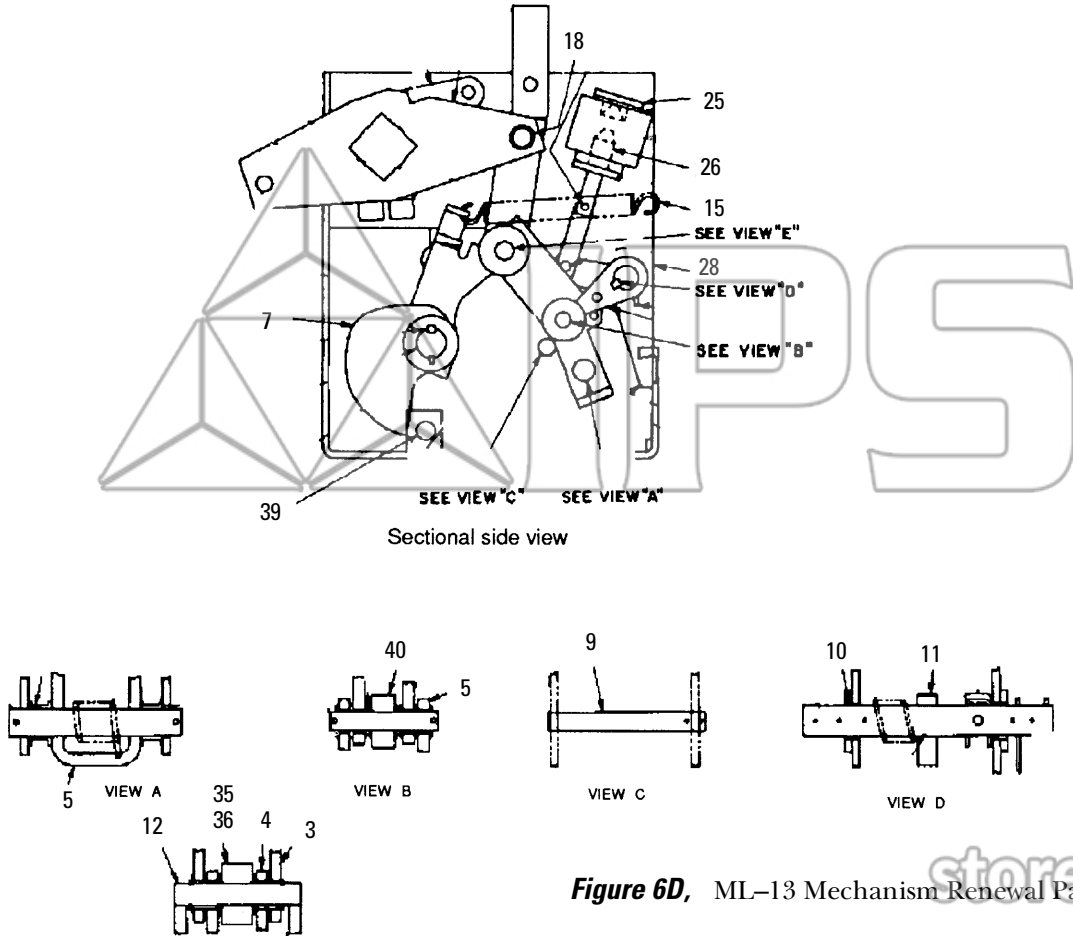

Figure 6D, ML-13 Mechanism Renewal Parts

Table 6I, ML-13 Mechanism Renewal Parts		
-See Figure 6D above		
Description	Ref. Number	Part Number
Link	3	0213X0702G012
Link	4	0213X0702G020
Link	4	0134C3585P003
Link	5	0213X0702G021
Cam	7	0105C9311G002
Stap Pin	9	0105C9304P003
Bushing	10	0456A0885P021
Latch (Trip)	11	0105C9302R002
Pin (Prop)	12	0105C9302P004
Shaft	18	0105C9308P004
Coil Support	25	0105C9316P002
Armature	26	0114C5347P004
Crank	28	0105C9316G001
Bearing (O.R.)	35	0414A0112P052
Bearing (I.R.)	36	0414A0112P053
Bearing (O.R.)	39	0414A0112P061
Bearing (O.R. & I.R.)	40	0414A0112P001
Bearing (O.R. & I.R.)	40	0414A0112P054

For more information contact your authorized GE sales representative or GE distributor.

Table 6J, AM Breaker 4.16–250–6, –7, –8, –9

Description Amps	Qty./Breaker	Breaker Type	Catalog Number
Movable Primary Contacts			
1200A	3	250–6	0137A9164P003
1200A	3	250–6	0137A9164P004
2000A	6	250–6	0137A9164P003
2000A	6	250–6	0137A9164P004
All	6	250–7–8–9	0114C5382P004 ²
All	6	250–7–8–9	0137A9164P003 ¹
All	6	250–7–8–9	0137A9164P004 ¹
Stationary Primary Contacts			
1200A	12	250–6	0236C0791P008
2000A	24	250–6	0236C0791P008
All	18	250–7–8–9	0114C5382P002
All	24	250–7–8–9	0114C5382P002
Primary Contact Springs			
1200A	12	250–6	0121A5964P001
1200A	18	250–9	0414A0180P001 ²
200A	24	250–9	0121A5964P001 ¹
2000A	24	250–6	006509787P001
2000A	18	250–9	0121A5964P001 ²
2000A	24	250–9	0121A5964P001 ¹
All	18	250–7–8	0121A5964P001
Movable Arcing Contacts			
All	3	250–6–7	0802B0742R003
All	3	250–8–9	0227A5306G004
Stationary Arcing Contacts			
All	3	250–6–7–8–9	0236C0790G009
Flexible Connector (Right)			
All	3	250–6–7–8–9	0236C0791G001
Flexible Connector (Left)			
All	3	250–6–7–8–9	0236C0791G004

¹ All breakers with “B” designation
² All breakers except “B” designation

Medium Voltage Circuit Breaker/Switchgear Parts

store.ips.us



Table 6K, AM Breaker 4.16–350–1

Description Amps	Qty./Breaker	Catalog Number
Movable Primary Contacts		
1200A	6	0137A9164P003
1200A	6	0137A9164P004
2000A	6	0137A9164P004
2000A	6	0137A9164P003
3000A	6	0114C5382P012
3000A	6	0114C5382P011
Stationary Primary Contacts		
2000A	24	0236C0791P008
2000A	24	0236C0791P008
3000A	36	0236C0791P008
Primary Contact Springs		
1200A	18	0414A0180P001
2000A	18	0414A0180P001
3000A	72	0414A0180P001
Movable Tertiary Contacts		
3000A	6	0619C0469P003
Stationary Tertiary Contacts		
3000A	12	0236C0791P008
Movable Arcing Contacts		
All	3	0802B0742R004
Stationary Arcing Contacts		
All	3	0383A0903G001
Flexible Connector		
All	3	0366A0413G001
Tube & Piston Assembly		
1200/2000A	3	0213X0343G046
3000A	3	0619C0473G003
Operating Rod Assembly		
1200/2000A	3	0281B0708R008
3000A	3	0802B0730R001
Box Barriers		
1200A/2000A	1	0619C0465G001
3000A	3	0619C0467G001
Booster Cylinder		
All	3	0619C0479P017

Medium Voltage Circuit Breaker/Switchgear Parts

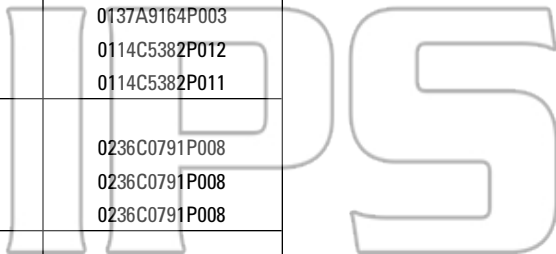

store.ips.us

For more information contact your authorized GE sales representative or GE distributor.

Courtesy of store.ips.us

Table 6L, AM Breaker 4.16–350–2

Description Amps	Qty./Breaker	Catalog Number
Movable Primary Contacts		
1200/2000A	6	0137A9164P005
1200/2000A	6	0137A9164P006
3000A	6	0114C5382P012
3000A	6	0114C5382P011
Stationary Primary Contacts		
1200/2000A	24	0114C5382P002
3000A	36	0114C5382P002
Primary Contact Springs		
1200/2000A	24	0121A5964P001
3000A	36	0414A0180P001
Movable Arcing Contacts		
1200/2000A	3	0227A5306G001
3000A	3	0227A5306G002
Stationary Arcing Contacts		
All	3	0213X0344R032
Flexible Connectors		
Left, Long	3	0208A8017G001
Right, Long	3	0208A8017G002
Left, Short	3	0208A8017G003
Right, Short	3	0208A8017G004
Tube & Piston Assembly		
1200/2000A	3	0213X0343R094
3000A	3	0132C2748R003
Operating Rod		
1200/2000A	3	0281B0708R008
3000A	3	0802B0730R001
Box Barriers		
1200A/2000A	1	0132C2742G001
3000A	3	0619C0467G001
Booster Cylinder		
All	3	0132C2745G001

Medium Voltage Circuit Breaker/Switchgear Parts

store.ips.us



GE Support Services

Table 6M, AM Breaker 7.2–500–6

Description Amps	Qty./Breaker	Catalog Number
Movable Primary Contacts		
1200/2000A	6	0114C5382P004
1200/2000A	6	0137A9164P003 ¹
1200/2000A	6	0137A9164P004 ¹
Stationary Primary Contacts		
1200/2000A	18	0114C5382P002 ²
1200/2000A	24	0114C5382P002 ¹
Primary Contact Springs		
1200/2000A	18	0121A5964P001
Movable Arcing Contacts		
All	3	0227A5306G001
Stationary Arcing Contacts		
All	3	0213X0344R032
Flexible Connectors		
Left, Long	3	0208A8017G001
Right, Long	3	0208A8017G002
Left, Short	3	0208A8017G003
Right, Short	3	0280A8017G004
Tube & Piston Assembly		
All	3	0213X0343R094
Operating Rod Assembly		
All	3	0281B0708R001
Box Barriers		
All	3	0265C0176R005
Booster Cylinder		
All	3	0263B0292P002

¹ All breakers with “B” designation
² All breakers except “B” designation

Medium Voltage Circuit Breaker/Switchgear Parts

store.ips.us

For more information contact your authorized GE sales representative or GE distributor.

Courtesy of store.ips.us

Table 6N, AM Breaker 13.8–500–5–6–7

Description Amps	Qty./Breaker	Breaker Type	Catalog Number
Movable Primary Contacts			
1200A	3	500–5	0137A9164P003
1200A	3	500–5	0137A9164P004
1200A	3	500–6,7	0137A9164P003 ²
1200A	3	500–6,7	0137A9164P004 ²
1200/2000A	6	500–6,7	0114C5382P004 ¹
2000A	6	500–5	0137A9164P003
2000A	6	500–5	0137A9164P004
2000A	6	500–6,7	0114C5382P004
Stationary Primary Contacts			
1200A	12	500–5	0114C5382P002
1200A	12	500–6,7	0114C5382P002 ²
1200A	18	500–6,7	0114C5382P002 ¹
2000A	24	500–5	0114C5382P002
2000A	18	500–6,7	0114C5382P002
Primary Contact Springs			
1200A	12	500–5,6,7	0414A0180P001 ²
1200A	24	500–5	0121A5964P001 ¹
1200A	18	500–6,7	0212A5964P001 ¹
2000A	24	500–5	006509787P001
2000A	18	500–6,7	0121A5964P001
Movable Arcing Contacts			
All	3	500–5	0802B0742R003
All	3	500–6,7	0227A5306G004
Stationary Arcing Contacts			
All	3	500–5,6,7	0236C0790G009
Flexible Connectors (Right)			
All	3	500–5,6,7	0236C0791G001
Flexible Connectors (Left)			
All	3	500–5,6,7	0236C0791G004
Tube & Piston Assembly			
1200A	3	500–5	0236C0792R031
2000A	3	500–5	0236C0792G015
1200/2000A	3	500–6	0213X0343R094
1200A	3	500–7	0213X0343R092
1200A	3	500–7	0213X0343R094
Operating Rod Assembly			
All	3	500–5,6,7	0281B0708R001
Box Barriers			
All	3	500–5,6	0265C0176G001
All	3	500–7	0152C5910R001
Booster Cylinder			
All	3	500–5,6,7	0263B0292P002

¹ All breakers with “B” designation

² All breakers except “B” designation

store.ips.us



98 Medium Voltage Circuit Breaker/Switchgear Parts

Table 6P, AM Breaker 13.8–750–4

Description Amps	Qty./Breaker	Catalog Number
Movable Primary Contacts		
1200/2000A	6	0114C5382P004 ²
1200/2000A	6	0137A9164P003 ¹
1200/2000A	6	0137A9164P004 ¹
Stationary Primary Contacts		
1200A	18	0114C5382P002 ²
1200A	24	0114C5382P002 ¹
Primary Contact Springs		
All	18	0121A5964P001 ²
All	24	0121A5964P001 ¹
Movable Arcing Contacts		
All	3	0227A5306G001
Stationary Arcing Contacts		
All	3	0213X0344G031
Flexible Connectors		
Right, Long	3	0208A8017G002
Right, Short	3	0208A8017G004
Left, Long	3	0208A8017G001
Left,, Short	3	0208A8017G003
Tube & Piston Assembly		
All	3	0213X0343R093
Operating Rod Assembly		
All	3	0281B0708R001 ²
All	3	0281B0708R007 ¹
Box Barriers		
All	3	0619C0419G008
Booster Cylinder		
All	3	0263B0292P002

¹ All breakers with “B” designation
² All breakers except “B” designation

Medium Voltage Circuit Breaker/Switchgear Parts

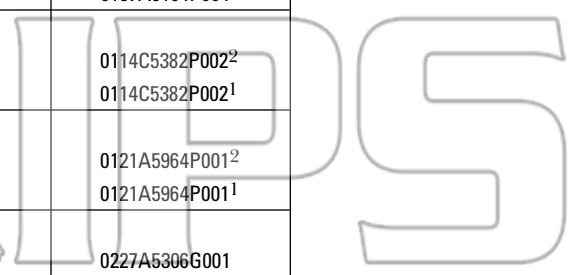

store.ips.us

For more information contact your authorized GE sales representative or GE distributor.

Courtesy of store.ips.us

Table 60, AM Breaker 13.8–750–5,6

<i>Description Amps</i>	<i>Qty./Breaker</i>	<i>Catalog Number</i>
Movable Primary Contacts		
All	6	0114C5382P004 ²
All	6	0137A9164P003 ¹
All	6	0137A9164P004 ¹
Stationary Primary Contacts		
All	18	0114C5382P002 ²
All	24	0114C5382P002 ¹
Primary Contact Springs		
All	18	0121A5964P001 ²
All	24	0121A5964P001 ¹
Movable Arcing Contacts		
All	3	0227A5306G001
Stationary Arcing Contacts		
All	3	0213X0344R032
Flexible Connectors		
Right, Long	3	0208A8017G002
Right, Short	3	0208A8017G004
Left, Long	3	0208A8017G001
Left, Short	3	0208A8017G003
Tube & Piston Assembly		
All	3	0213X0343R094
Operating Rod Assembly		
All	3	0281B0708R001
All	3	0165B7903G007 ¹
Box Barriers		
All	3	0265C0176R006
Booster Cylinder		
All	3	0263B0292P002

¹ All breakers with “B” designation

² All breakers except “B” designation

Medium Voltage Circuit Breaker/Switchgear Parts

store.ips.us



GE Support Services

100 Medium Voltage Circuit Breaker/Switchgear Parts

Table 6R, AM Breaker 13.8–1000–3

Description Amps	Qty./Breaker	Catalog Number
1200/2000A	3	0688C0595P022
1200/2000A	3	0688C0595P021
1200/2000A	3	0137A9164P004
1200/2000A	3	0137A9164P003
3000A	3	0688C0595P023
3000A	3	0688C0595P024
3000A	3	0114C5382P011
3000A	3	0114C5382P012
Stationary Primary Contacts		
1200/2000A	24	0236C0791P008
3000A	36	0236C0791P008
Primary Contact Springs		
1200/2000A	24	0414A0180P001
3000A	36	0414A0180P001
Movable Tertiary Contacts		
3000A	6	0619C0469P003
Stationary Tertiary Contacts		
3000A	12	0236C0791P008
Movable Arcing Contacts		
1200/2000A	3	0966C0353G001
3000A	3	0966C0353G002
Stationary Arcing Contacts		
1200/2000A	3	0966C0354R002
3000A	3	0966C0354G003
Flexible Connectors		
Right	3	0966C0351G004
Left	3	0966C0351G003
Tube & Piston Assembly		
1200/2000A	3	0213X0343G048
3000A	3	0966C0355G006
Operating Rod Assembly		
1200/2000A	3	0281B0708R007
3000A	3	0688C0520G001
Box Barriers		
1200A	3	0105C9373G001
2000A	3	0105C9373G003
3000A	3	0105C9373G002
Booster Cylinder		
1200/2000A	3	0114C5308G003
3000A	3	0114C5308G004

Medium Voltage Circuit Breaker/Switchgear Parts

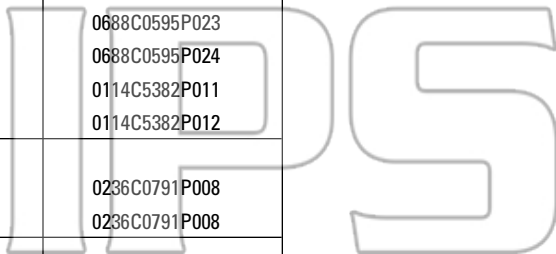

store.ips.us

For more information contact your authorized GE sales representative or GE distributor.

Courtesy of store.ips.us

Table 6S, AM Breaker 13.8–1000–4

Description Amps	Qty./Breaker	Catalog Number
Movable Primary Contacts		
1200/2000A	6	0137A9164P003
1200/2000A	6	0137A9164P004
3000A	6	0114C5382P012
3000A	6	0114C5382P011
Stationary Primary Contacts		
1200/2000A	24	0114C5382P002
3000A	36	0114C5382P002
Primary Contact Springs		
1200/2000A	24	0121A5964P001
3000A	36	0414A0180P001
Movable Tertiary Contacts		
3000A	6	0619C0469P003
Stationary Tertiary Contacts		
All	3	0114C5382P002
Movable Arcing Contacts		
1200/2000A	24	0227A5306G001
3000A	36	0227A5306G003
Stationary Arcing Contacts		
All	3	0213X0344R032
Flexible Connectors		
Right, Long	3	0208A8017G002
Right, Short	3	0208A8017G004
Left, Long	3	0208A8017G001
Left, Short	3	0208A8017G003
Tube & Piston Assembly		
1200/2000A	3	0213X0343R094
3000A	3	0132C2748R003
Operating Rod Assembly		
1200/2000A	3	0281B0708R001
3000A	3	0134C3582R001
Box Barriers		
1200A	3	0105C9373G001
2000A	3	0105C9373G003
3000A	3	0105C9373G002
Booster Cylinder		
All	3	0263B0292P002

Medium Voltage Circuit Breaker/Switchgear Parts

store.ips.us



GE Support Services

102 Medium Voltage Circuit Breaker/Switchgear Parts

Table 6T, GE /VAC Circuit Breaker

Breaker Type	Amps	Front Bushing	Rear Bushing	Operating Rod Asmy.	Vacuum Interr.
4.16-250-0	1200A	0845D0123G001	0845D0124G001	0172C7625G001	0186L0739P056
	2000A	0688C0515G001	0688C0516G006	0172C7625G001	0186L0739P056
4.16-250-1	1200A	0845D0123G001	0845D0124G001	0172C7624G001	0183L0739P056
	2000A	0688C0515G001	0688C0516G006	0172C7624G001	0186L0739P056
7.2-500-0	1200A	0845D0123G003	0845D0124G003	0172C7624G001	0186L0739P041
	2000A	0958C0683G003	0958C0684G005	0172C7624G001	0186L0739P041
7.2-500-1	1200A	0845D0123G003	0845D0124G003	0172C7624G001	0186L0739P041
	2000A	0958C0683G003	0958C0684G005	0172C7624G001	0186L0739P041
13.8-500-0	1200A	0845D0123G003	0845D0124G003	0172C7624G001	0186L0739P055
	2000A	0958C0683G003	0958C0684G005	0172C7624G001	0186L0739P055
13.8-500-1	1200A	0845D0123G003	0845D0124G003	0172C7624G001	0186L0739P055
	2000A	0958C0683G003	0958C0684G005	0172C7624G001	0186L0739P055
13.8-750-0	1200A	0845D0123G003	0845D0124G003	0172C7624G001	0186L0739P041
	2000A	0958C0683G003	0958C0684G005	0172C7624G001	0186L0739P041
13.8-750-OL	1200A	0845D0123G004	0845D0124G007	0172C7624G001	0186L0739P041
	2000A	0265C0188G007	0132C2725G001	0172C7624G001	0186L0739P041
13.8-750-1	1200A	0845D0123G003	0845D0124G003	0172C7624G001	0186L0739P041
	2000A	0958C0683G003	0958C0684G005	0172C7624G001	0186L0739P041
13.8-750-1L	1200A	0845D0123G004	0845D0124G007	0172C7624G003	0186L0739P044
	2000A	0265C0188G007	0132C2725G001	0172C7624G003	0186L0739P044
	3000A	0172C7638G002	0172C7638G001	0172C7624G003	0186L0739P043
13.8-1000-1-0	1200A	0845D0123G004	0845D0124G007	0172C7624G003	0186L0739P044
	2000A	0265C0188G007	0132C2725G001	0172C7624G003	0186L0739P044
	3000A	0172C7638G002	0172C7638G001	0172C7624G003	0186L0739P043

Medium Voltage Circuit Breaker/Switchgear Parts

store.ips.us

For more information contact your authorized GE sales representative or GE distributor.

Courtesy of store.ips.us

Vertical Lift Metal-Clad Switchgear

Included in this Section

Metal-Clad Switchgear is equipment to control and protect various types of electrical apparatus and power circuits. This type of Switchgear consists of one or more units which are mounted side by side and connected mechanically together to form a complete switching equipment.

M-26 and M-36
For AM and Vacuum Circuit Breakers 4.16 and 13.8 kv

Equipment Identification and Nomenclature Guide

- Furnish the complete nameplate data of switchgear for identification purposes.
- Specify quantity, catalog number, item number, and description for each part.
- Nameplate is located in left most breaker cubicle.
- For pricing, proper installation and maintenance instructions, contact your local GE sales and/or service representative

M-26 for 5 kV 26"
M-36 for 15 kV 36"

store.ips.us

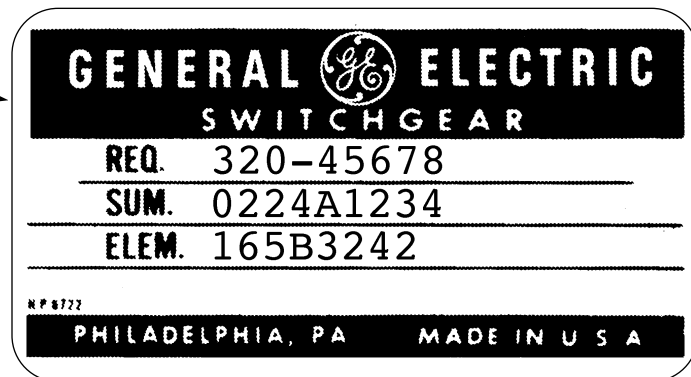

Figure 7, Vertical Lift Metal-Clad Switchgear Nameplate Data



104 Medium Voltage Circuit Breaker/Switchgear Parts

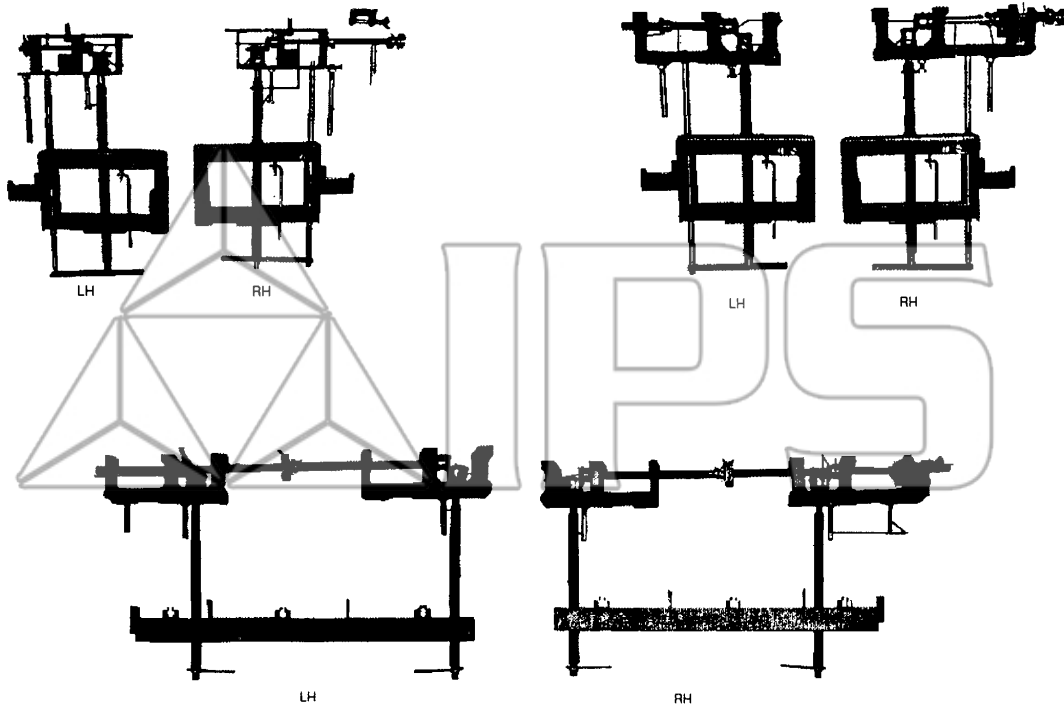

Figure 7A, Vertical Lift Metal-Clad Elevating Mechanisms

store.ips.us

Table 7A, Metal-Clad Switchgear Elevating Mechanisms

–See Figure 7A above

Equipment Design	Breaker Rating	Fig. Number	Left Hand	Right Hand
M26	4.16–250–1200	1	0834C0194G009	0834C0194G008
M26	4.16–250–2000	1	0834C0194G009	0834C0194G008
M26H	4.16–350–1200	1	0832C0481G002	0832C0481G001
M26H	4.16–350–2000	1	0832C0481 G002	0832C0481 G001
M26H	4.16–350–3000	2	0685C0957G005	0685C0957G004
M36	7.2–500–1200	1	0834C0194G010	0834C0194G007
M36	7.2–500–2000	2	0829C0485G009	0829C0485G008
M36	13.8–500–1200	1	0834C0194G010	0834C0194G007
M36	13.8–500–2000	2	0829C0485G009	0829C0485G008
M36HN	13.8–750–1200	1	0834C0194G010	0834C0194G007
M36HN	13.8–750–2000	2	0829C0485G009	0829C0485G008
M36H	13.8–750–1200	2	0265C0267G005	0265C0267G004
M36H	13.8–750–2000	2	0265C0267G005	0265C0267G004
M36HH	13.8–1000–1200	3	0828C0486G004	0828C0486G003
M36HH	13.8–1000–2000	3	0828C0486G004	0828C0486G003
M36HH	13.8–100–3000	3	0828C0486G002	0828C0486G001

For more information contact your authorized GE sales representative or GE distributor.

**Table 7B, Metal-Clad Switchgear
Breaker Elevating Motors**

Voltage	Part Number
115V AC/125V DC	0685C0810G004
230V AC/250V DC	0685C0810G005
Remote Elevating Motors	
Voltage	Part Number
115V AC/125V DC	0687C0879G001
230V AC/250V DC	0687C0897G003

**Table 7C, Metal-Clad Switchgear Primary Disconnects
-See Figure 7B below**

Front and Rear Primary Disconnects Available for:

M-26	M36	M36HN
M26H	M36H	M36HH

Front and rear primary disconnects are manufactured by GE. Due to the uniqueness of switchgear cubicles, it is not possible to publish a standard list. Please furnish nameplate summary number and unit number with your request.

store.ips.us

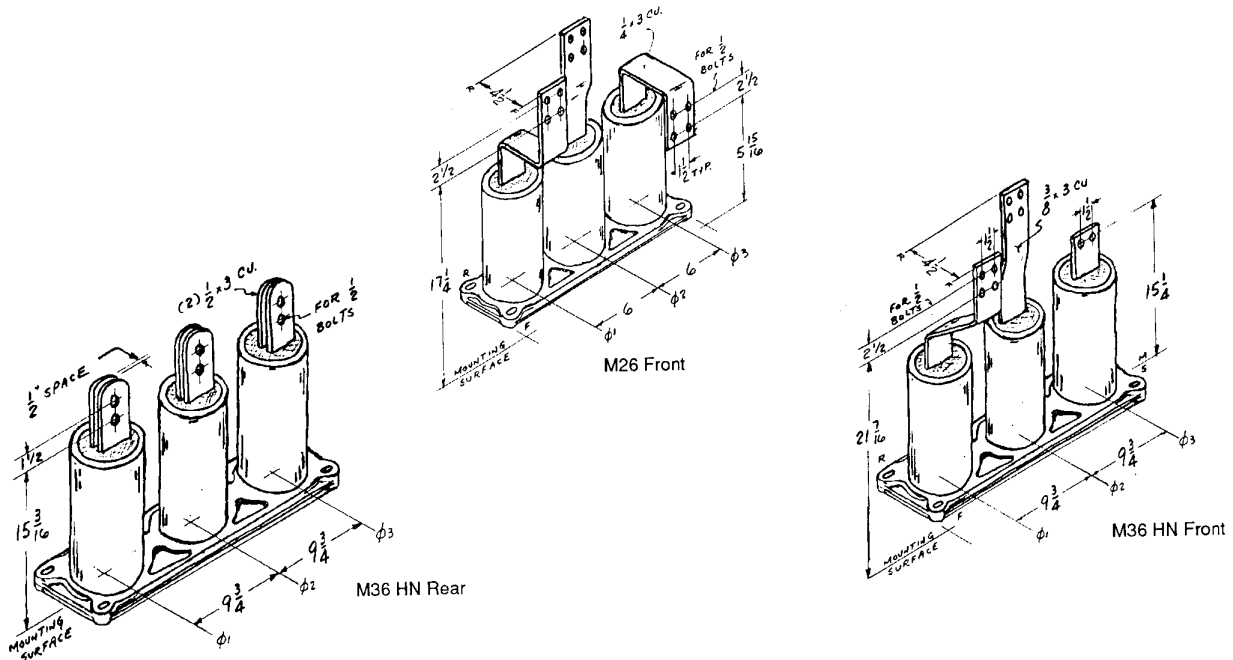

Figure 7B, Vertical Lift Metal-Clad Primary Disconnects



GE Support Services

Medium Voltage Circuit Breaker/Switchgear Parts

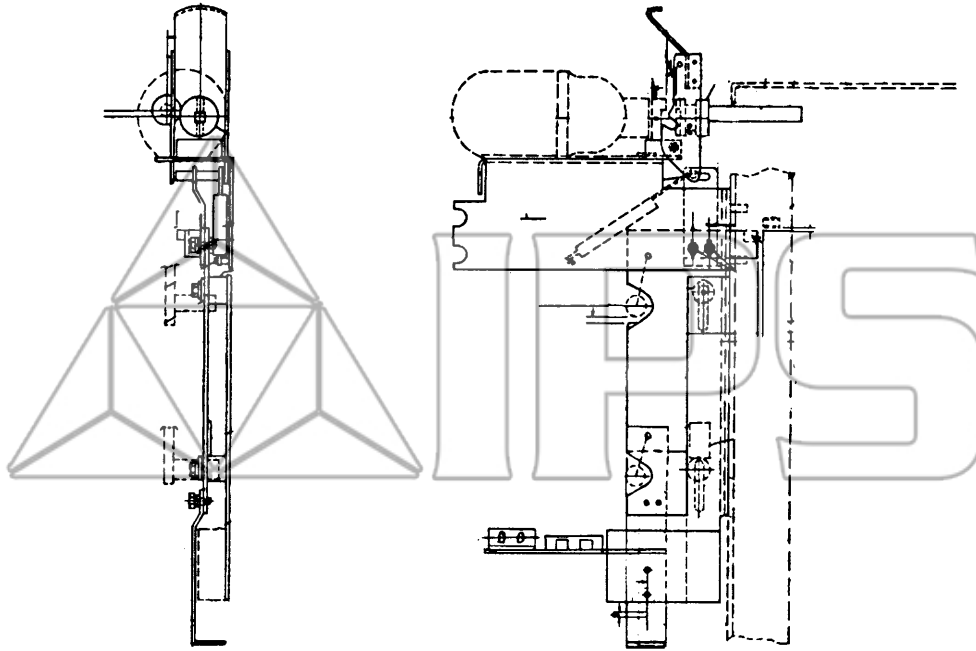

Figure 7C, Vertical Lift Metal-Clad Positive Interlock Assembly for M36

Table 7D, Metal-Clad Switchgear Positive Interlock Assembly – See Figure 7C above

Positive Interlocks	Equipment Design	Catalog Number
4.16–250–1200	M26	006519802G004
4.16–250–2000	M26	006519802G004
4.16–350–1200	M26H	006517965G004
4.16–350–2000	M26H	006517965G004
4.16–350–3000	M26H	006517965G006
7.2–500–1200	M36	006517965G005
7.2–500–2000	M36	006517965G004
13.8–750–1200	M36H	0265C0235G002
13.8–750–2000	M36H	0265C0235G002
13.8–500–1200	M36	006517965G005
13.8–500–2000	M36	006517965G004
13.8–750–1200	M36HN	006517965G005
13.8–750–2000	M36HN	006517965G004
13.8–1000–1200	M36HH	0829C0463G001
13.8–1000–2000	M36HH	0829C0463G001
13.8–1000–3000	M36HH	0829C0463G001

For more information contact your authorized GE sales representative or GE distributor.

**Table 7E, Metal-Clad Switchgear
Bus Insulation, Tape, Grease – See Figure 7D & E below**

Bus Size	Catalog Number		
1/4 x 4 x 92 5/8 in.	0161A5075P001		
3/8 x 4 x 92 5/8 in.	0161A5076P001		
3/8 x 6 x 92 5/8 in.	0161A5077P001		
5/8 x 6 x 92 5/8 in.	0161A5078P001		
1/2 x 6 x 92 5/8 in.	0161A5080P001		
Tapping Kits (3 Connections)			
	0172A8835G003 (15 kv)		
	0172A8835G012 (5 kv)		
Description	Size	Catalog Number	
Irrathene Tape	1 1/2" Wide (Ref. 1)	0226A8265P042	
Glass Tape	1 1/2" Wide (Ref. 2)	0226A8265P046	
Joint Compound	5 LB. Can (Ref. 4)	0226A8265P048	
Red Varnish (U310) 15 kv	Quart Can (Ref. 3)	0226A8295P050	
Black Varnish (U311) 5 kv	Quart Can (Ref. 3)	0226A8265P051	
Grease—Catalog Number	GE Spec.	Color	Size
0269A3691AAP108	D50H109	Yellow	4 oz.
0269A3691AAP109	D50H15	White	4 oz..
0183L0907P037	D6A15A1	Red	4 oz.

Medium Voltage Circuit Breaker/Switchgear Parts

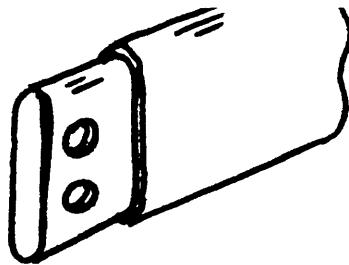

Figure 7D, Bus Insulation

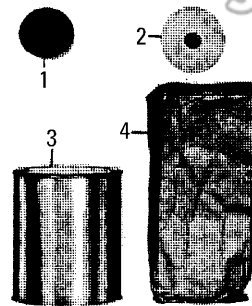

Figure 7E, Taping Kits

store.ips.us



GE Support Services

108 Medium Voltage Circuit Breaker/Switchgear Parts

**Table 7F, Metal-Clad Switchgear
Renewal Parts –See surrounding Figures**

Chains Ratings	
4.16–250–1200/2000A	0226A8265P003
7.2–500–1200A	0226A8265P004
13.8–500–1200A	0226A8265P004
13.8–750–1200A	0226A8265P004
7.2–500–2000A	0226A8265P025
13.8–500–2000A	0226A8265P025
13.8–750–2000A	0226A8265P025
Door Handles	
Door Handle–Ref. 1	006539892P003
Door Handle–Ref. 2	006533892P004
Door Handle–Ref. 3	006533892P001
Door Handle–Ref. 4	006533892P002
Door Handle–Ref. 5	006533892P005
Auto-Charge Cap.Trip	0177C3941701
Capacitor Trip Device	0105C9380G003
Silicon Rectifier	0962C0670G001—Up to 65 Amps 0105C3009G001—65 Amps and Above
Heaters	
115V,250W	0269A3691MP042
230V,250W	0269A3690612
Fuse Blocks	
30 AMP,250V	0132A1578001
60AM P,250V	0132A1578002
Mercury Switches	
Cubical Position–Upper	0172C7622G001
Cubical Position–Lower	0172C7622G002
Cubical Position–Front Enclosure	0172C7622G003
Cubical Position–All Three	0172C7622G004

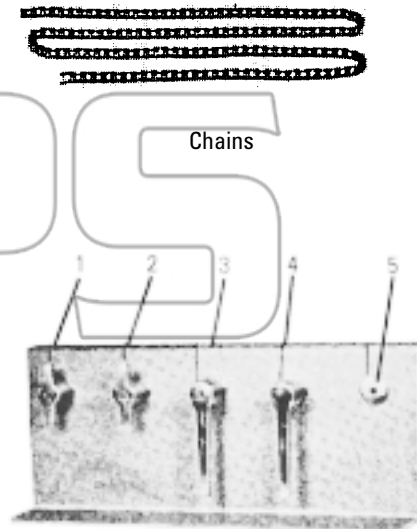

Chains
Door Handles



Auto-charged
Capacitor Trip Device



Capacitor Trip Device

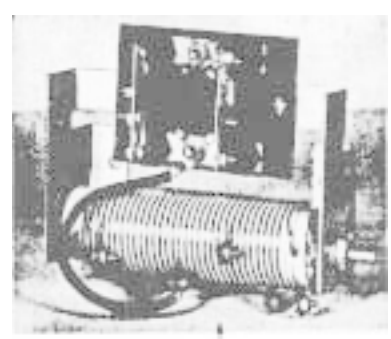

Silicon Rectifiers for Circuit
Breaker Closing Service

For more information contact your authorized GE sales representative or GE distributor.

Medium Voltage Circuit Breaker/Switchgear Parts